

- NOTES:
 1. CUSTOM FOR VARIATION OF VITA 42 XMC STANDARD & ITEMS -1, -2, & -3 NOT AVAILABLE AS STANDARD.
 2. Ⓞ REPRESENTS A CRITICAL DIMENSION.
 3. BURR ALLOWANCE: .0015[0.038] MAX.
 4. MAXIMUM CUT FLASH: .010[0.25].
 5. MINIMUM PUSHOUT FORCE: .5 LB.
 6. MAXIMUM ALLOWABLE BOW: TOP/BOTTOM: .004[0.10], SIDE/SIDE: .003[0.08].
 7. PARTS TO BE PACKAGED IN TAPE & REEL. FOR QTY'S LESS THAN 125 PCS, NO TRAILER OR LEADER WILL BE SUPPLIED.

ANY REV MADE TO THIS PRINT MUST HAVE AN UPDATED MKT PRINT

DO NOT SCALE FROM THIS PRINT

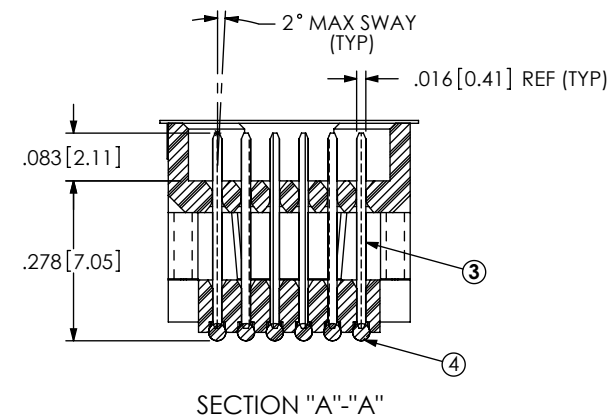
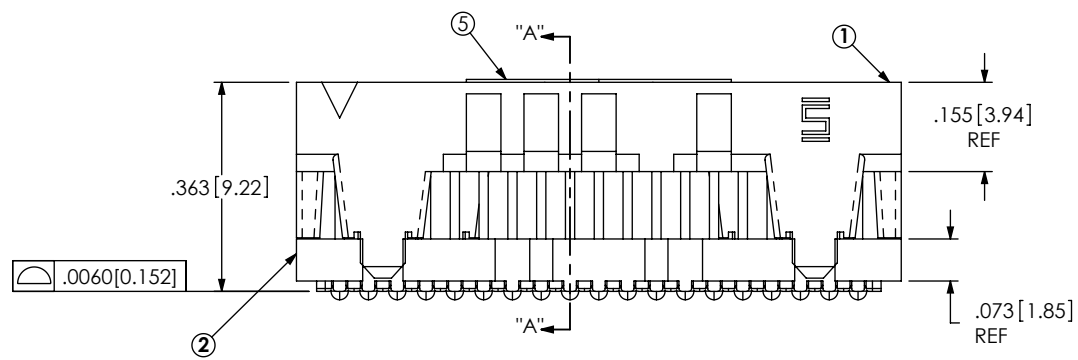
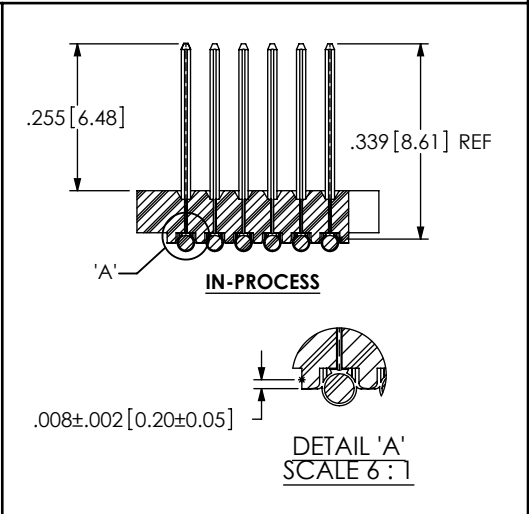
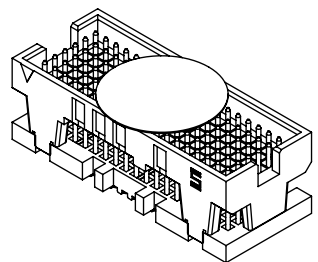
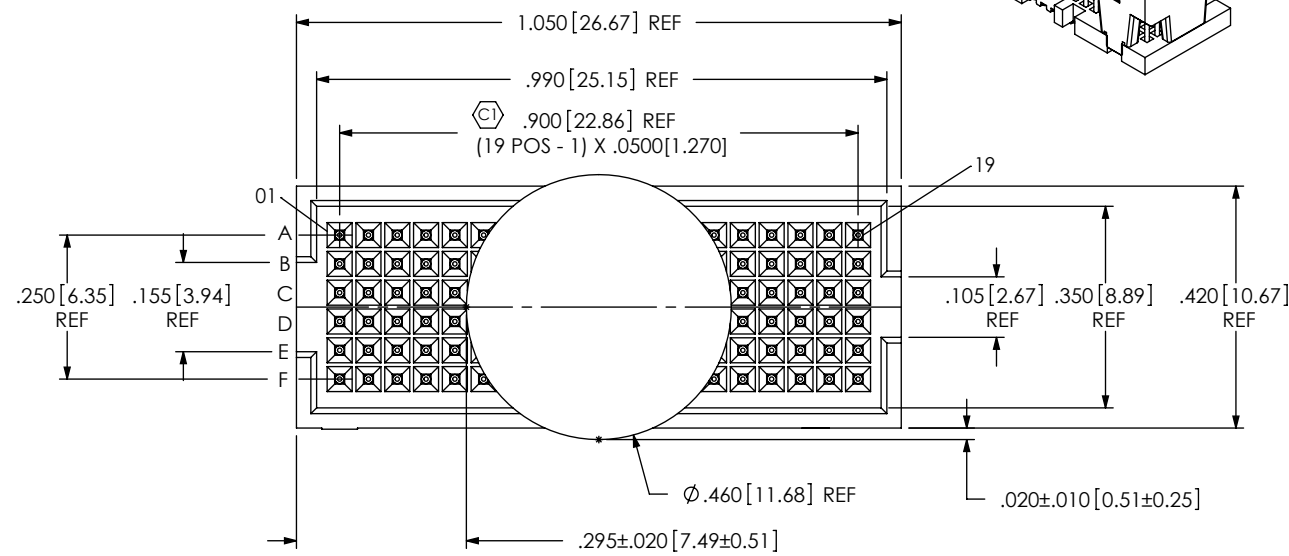

ITEM NO.	PART NUMBER	QTY	MATERIAL
1	ASP-103598-01-B	1.0000	UL 94 V0, COLOR: BLACK
2	ASP-103599-01-B	1.0000	UL 94 V0, COLOR: BLACK
3	ASP-104554-02-P-H	114.00	BRASS ALLOY 260, 3/4 HARD
4	SBD-030-6337	114.00	63% TIN /37% LEAD
5	K-850-650	1.0000	POLYIMIDE FILM
6	CT-ASP1134MS	.0057	CONDUCTIVE POLYMER

UNLESS OTHERWISE SPECIFIED, DIMENSIONS ARE IN INCHES. TOLERANCES ARE:
 DECIMALS ANGLES
 .XX: ±.01 2°
 .XXX: ±.005
 .XXXX: ±.0020

PROPRIETARY NOTE
 THIS DOCUMENT CONTAINS INFORMATION CONFIDENTIAL AND PROPRIETARY TO SAMTEC, INC. AND SHALL NOT BE REPRODUCED OR TRANSFERRED TO OTHER DOCUMENTS OR DISCLOSED TO OTHERS OR USED FOR ANY PURPOSE OTHER THAN THAT WHICH IT WAS OBTAINED WITHOUT THE EXPRESSED WRITTEN CONSENT OF SAMTEC, INC.



520 PARK EAST BLVD. NEW ALBANY, IN 47150
 PHONE: 812-944-6733 FAX: 812-948-5047
 e-Mail: info@SAMTEC.com code 55322

DO NOT SCALE DRAWING SHEET SCALE: 3:1
 PLATING ON ENTIRE TERMINAL:
 .00030 GOLD OVER .000050 NICKEL

DESCRIPTION: VITA 42 (LEADED) 10MM MATED SOCKET ASSEMBLY

DWG. NO. ASP-103614-01

BY: CLAY W 10/18/2002 SHEET 1 OF 2

RECOMMENDED BOARD LAYOUT

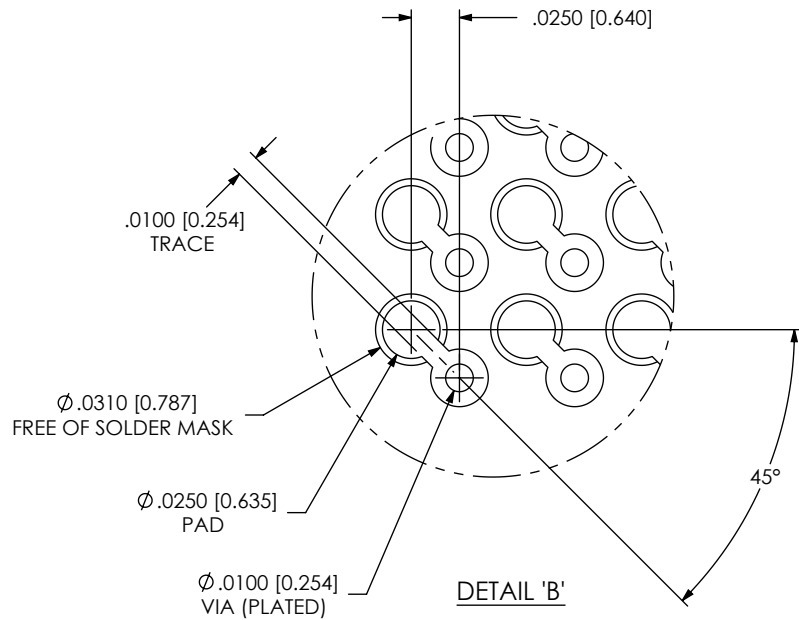
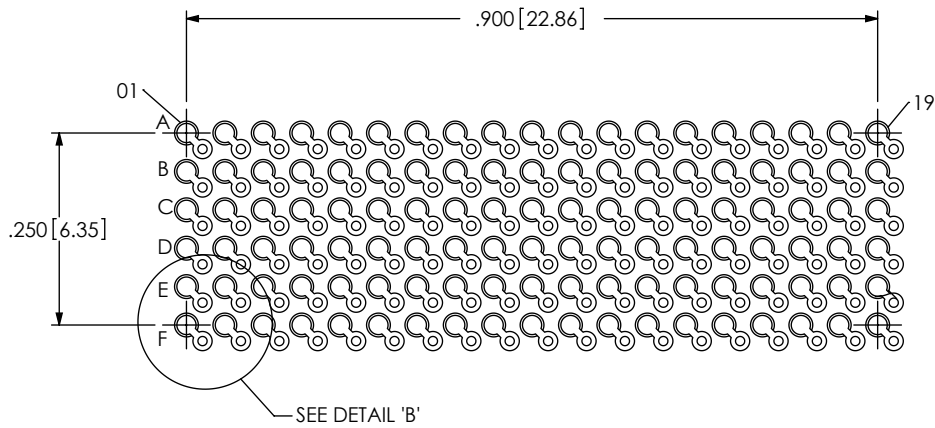

RECOMMENDED STENCIL LAYOUT
STENCIL TO BE .0060[0.152] THICK

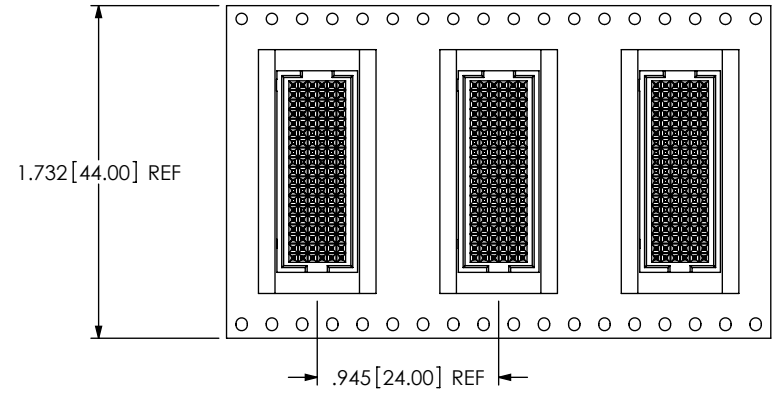
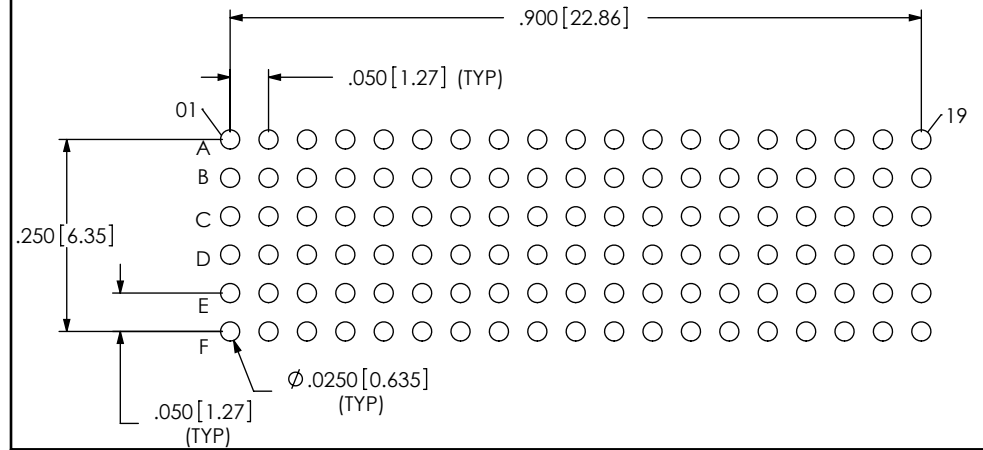

USER DIRECTION OF UN-REELING
POCKET NOT DETAILED

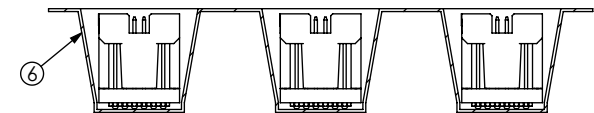

PACKAGING VIEW

C:\Enterprise Vault\DWG\MISC\MKTG\ASP-103614-01-MKT.SLDDRW

PROPRIETARY NOTE

THIS DOCUMENT CONTAINS INFORMATION CONFIDENTIAL AND PROPRIETARY TO SAMTEC, INC. AND SHALL NOT BE REPRODUCED OR TRANSFERRED TO OTHER DOCUMENTS OR DISCLOSED TO OTHERS OR USED FOR ANY PURPOSE OTHER THAN THAT WHICH IT WAS OBTAINED WITHOUT THE EXPRESSED WRITTEN CONSENT OF SAMTEC, INC.



520 PARK EAST BLVD, NEW ALBANY, IN 47150
PHONE: 812-944-6733 FAX: 812-948-5047
e-Mail: info@SAMTEC.com code 55322

SHEET SCALE: 4:1

DESCRIPTION:
VITA 42 (LEADED) 10MM MATED SOCKET ASSEMBLY

DWG. NO.
ASP-103614-01

BY: CLAY W 10/18/2002 SHEET 2 OF 2