

TOP FEEDING REEL WINDING DIRECTION

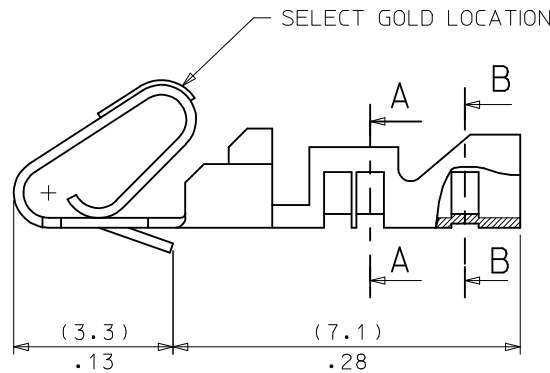
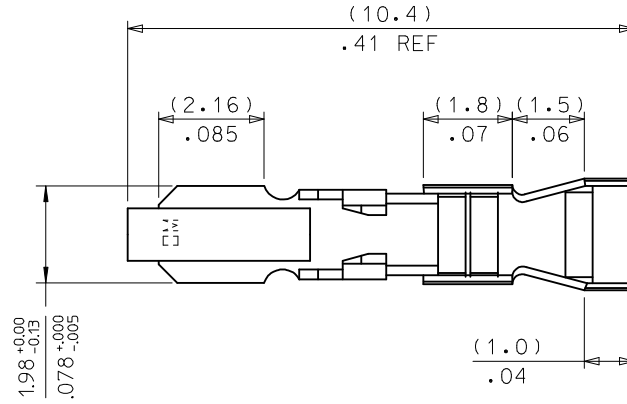
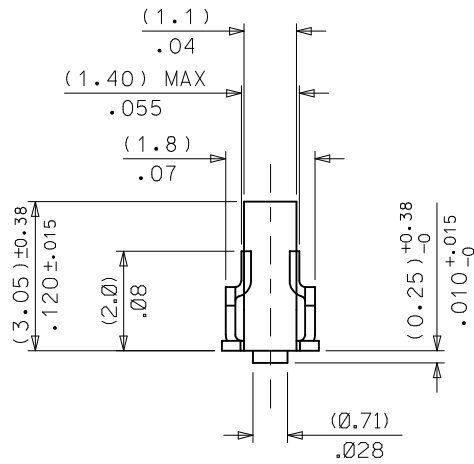

PART No.	ENG No.	FORM	FINISH
08-65-0105	8088-(555)	CHAIN	555
08-65-0106	8088-(555)L	LOOSE	

LEGEND

8088-(***)*
 PLATING CODE ——— BLANK = CHAIN FORM, TOP FEEDING REEL
 L = LOOSE FORM

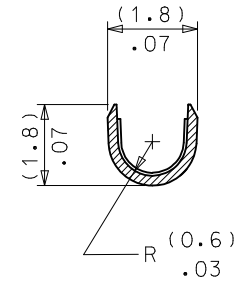

A-A

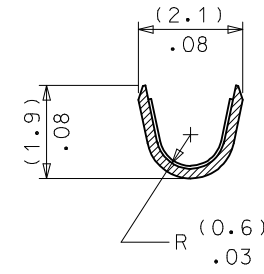

B-B

NOTES:

1. MATERIAL: PHOS. BRONZE
2. FINISH:
555 = 0.00038/.000015 MIN. SELECT GOLD IN CONTACT AREA OVER (0.00076)/.000030 MIN. NICKEL OVERALL
3. PRODUCT SPECIFICATION: PS-99020-0088.
4. FOR 22-30 AWG WIRE: (1.57)/.062 DIA MAX INSULATION
5. THIS PART CONFORMS TO CLASS B REQUIREMENTS OF MOLEX COSMETIC SPECIFICATION PS-45499-002.

CUT-OFF TOLERANCE EC NO: UCP2013-5579 DRAWN: KIPPER 2013/06/27 CHKD: BELL 2013/06/27 APPR: F SMITH 2013/07/16	QUALITY SYMBOLS	GENERAL TOLERANCES (UNLESS SPECIFIED)	DIMENSION STYLE	SCALE	DESIGN UNITS	THIRD ANGLE PROJECTION
	▽E=0	4 PLACES ± --- ± ---	MM/IN	10:1	METRIC	☉
	▽E=0	3 PLACES ± --- ± .010				
	▽E=0	2 PLACES ± 0.25 ± .020				
		1 PLACE ± 0.51 ± ---				
		0 PLACE ± ±				
		ANGULAR ± 1/2°				
		DRAFT WHERE APPLICABLE MUST REMAIN WITHIN DIMENSIONS				
			MATERIAL NO.	DOCUMENT NO.		SHEET NO.
			SEE CHART	SD-8088-****		1 OF 1
			THIS DRAWING CONTAINS INFORMATION THAT IS PROPRIETARY TO MOLEX INCORPORATED AND SHOULD NOT BE USED WITHOUT WRITTEN PERMISSION			