

DRAWING MADE IN THIRD ANGLE PROJECTION

566392 566392

PART NUMBER	REV	FIRST USED	MACHINE REFERENCE	FEED TYPE
566392-1	F	356462-2	G-SPLICE TERM	AIR FEED
566392-2	G	2161300-1	SK CE & GI THRU SPLICE	AIR FEED
7-566392-7	F	356462-2	SPARE PARTS KIT	-
7-566392-8	G	-	COM. KIT FOR -1 TO -2	-

TERMINAL NAME: SPLICE					
61769					
CRIMPING DATA					
PAD NO.	CRIMP HEIGHT		WIRE SIZE	WIRE SET UP	
4	.074	±.002 [1.88 ±0.05mm]	2250-2600 CMA	(1)18 & (1)22	
4	.072	±.002 [1.83 ±0.05mm]	1900-2250 CMA	(2)20	
3	.069	±.002 [1.75 ±0.05mm]	1550-1900 CMA	(1)20 & (1)22	
3	.066	±.002 [1.68 ±0.05mm]	1200-1550 CMA	(2)22	
CRIMP	SIZE	TYPE	RANGE		
WIRE	.090 [2.29mm]	F	1,200-2,600 CMA		
INSUL	-	-	-		
WIRE STRIP LENGTH	TERM APPL SPEC	FEED	APPL INSTRUCTION	SET UP GAGE	LAYOUT
.165-.205	114-2088	.350	408-8318(-1) 408-127000(-2)	-	12290

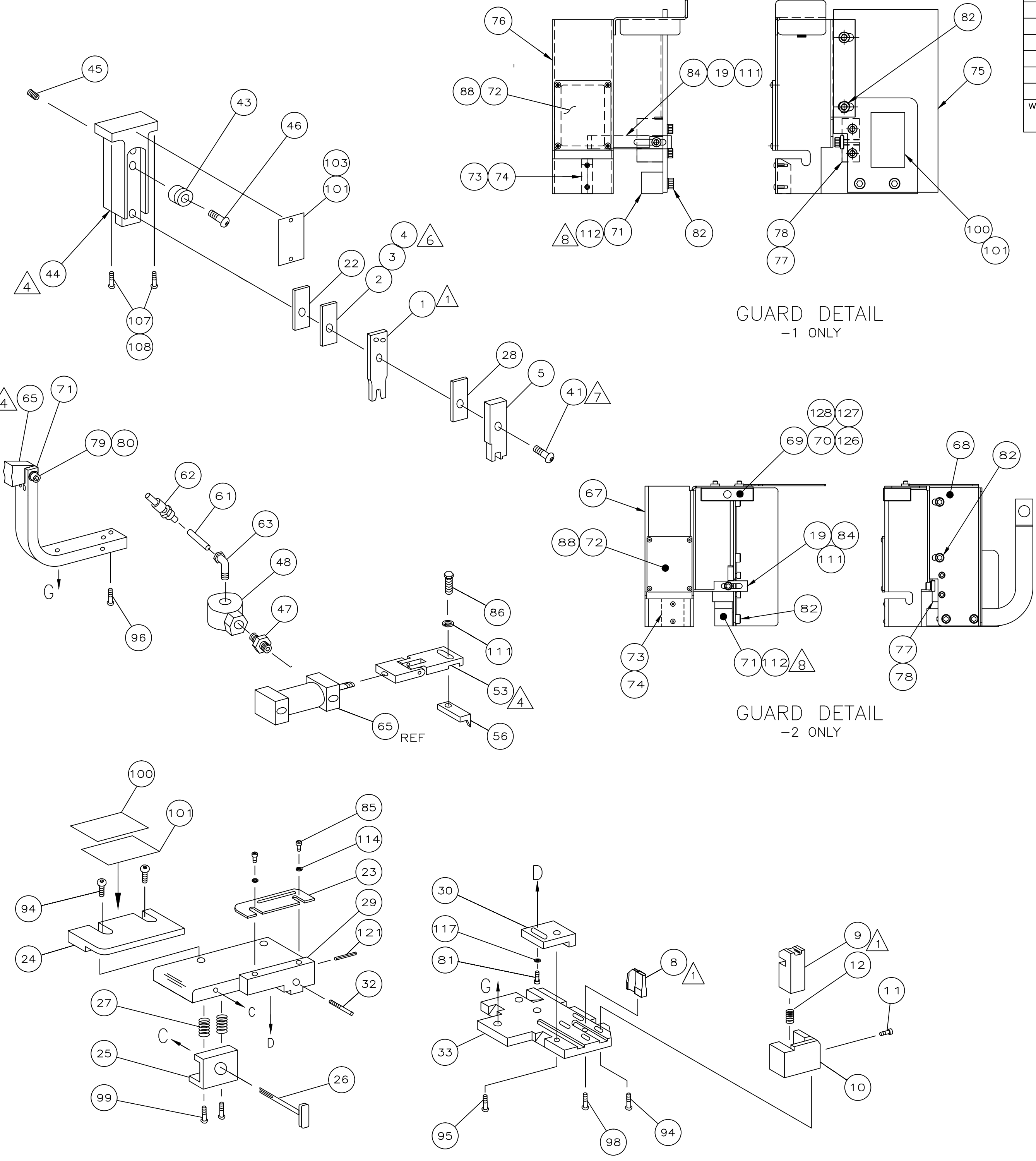

GUARD DETAIL
-1 ONLY

GUARD DETAIL
-2 ONLY

QTY	REQD PER ASSY	PART NO	DESCRIPTION	ITEM NO		
2	-	2	-	18029-2	M4 HEX NUT	128
2	-	2	-	18025-2	M4 LOCK WASHER	127
2	-	2	-	18027-2	M4 FLAT WASHER	126
1	-	1	-	408-32162	THRU SPLICE IS SHEET-GII	125
-	-	1	1	217238-1	GENERAL INSTRUCTION PACKAGE	124
-	-	-	1	408-8318	THRU SPLICE IS SHEET	123
-	-	1	-	408-127000	THRU SPLICE IS SHEET	122
-	-	1	1	4-21028-0	PIN,SLT SPR(Ø.093x.75)ST GDE PL	121
-	-	-	-	-	-	120
-	-	-	-	-	-	119
-	-	-	-	-	-	118
-	-	1	1	21024-5	WASHER, LOCK(#10)ADJ BLOCK	117
-	-	-	-	-	-	116
-	-	-	-	-	-	115
-	-	2	2	21024-2	WASHER,LOCK(#4)FRONT STP GUIDE	114
-	-	-	-	-	-	113
-	-	AR	AR	21899-2	WASHER, FLAT (#10)	112
-	-	2	2	21024-4	WASHER,LOCK(#8)STRIPPER	111
-	-	-	-	-	-	110
-	-	-	-	-	-	109
2	-	2	-	3-18023-3	SCR,SHC (M6 X 50)	108
-	-	-	2	2-18023-9	SCR,SHC(M6x20)	107
-	-	-	-	-	-	106
-	-	-	-	-	-	105
-	-	-	-	-	-	104
-	-	1	1	690701-2	PLATE,ID	103
-	-	-	-	-	-	102
-	-	AR	AR	25527-3	TAPE, POLYURETHANE FOAM	101
-	-	1	1	819347-1	PLATE, IDENTIFICATION	100
-	-	2	2	3-21002-0	SCR,BHC(10-32x.88)DRAG	99
-	-	1	1	22733-8	SCR,BHC(8-32x.38 LW)ANVIL	98
-	-	-	-	-	-	97
-	-	2	2	2-22733-8	SCR,BHC(1/4-20x.62)FEED	96
-	-	1	1	2-21002-7	SCR,BHC(10-32x.50)SG ADJ BLK	95
-	-	4	4	2-21002-2	SCR,BHC(8-32x.50)TERM H DWN	94
-	-	-	-	-	-	89
-	-	4	4	1-21002-0	SCR,BHC(2-56X.25)GUARD	88
-	-	-	-	-	-	87
-	-	1	1	2-22603-1	SCR,HEX HD(8-32x.38)FEED FINGER	86
-	-	2	2	1-21000-3	SCR,SHC(4-40x.25)F ST GUIDE	85
-	-	1	1	2-21000-7	SCR,SHC(8-32x.50)STRIPPER	84
-	-	-	-	-	-	83
-	-	4	4	3-21000-4	SCR,SHC(10-32x.38)GUARD	82
-	-	1	1	3-22603-1	SCR,HEX(10-32x.38)SG ADJ BL	81
-	-	1	1	3-21001-3	SCR,SHC(3/8-16x.75)	80
-	-	1	1	21024-8	WASHER,LOCK(3/8)	79
-	-	1	1	1338118-1	MOUNT, STRIPPER	78
-	-	2	2	1-21000-9	SCR,SHC(6-32x.38)GUARD	77
-	-	-	-	-	-	76
-	-	-	-	-	-	75
-	-	1	1	1338176-1	GUARD, EXTENSION	74
-	-	1	1	1338177-1	DEFLECTOR	73
-	-	2	2	21002-9	SCR, BHC 2-56 X .25 LG.	72
-	-	1	1	1338174-1	WINDOW, GUARD	71
-	-	1	1	1338116-1	BRACKET, FEED	70
-78	-77	-2	-1			

QTY	REQD PER ASSY	PART NO	DESCRIPTION	ITEM NO		
2	-	2	-	1-18023-3	SCR, SHC, M4 X 16	70
1	-	1	-	2168489-1	ACTUATOR, SPARE MC1	69
1	-	1	-	2161461-1	GUARD, EXTENSION	68
1	-	1	-	2161460-1	GUARD	67
-	-	-	-	-	-	66
-	-	1	1	461065-1	AIR FEED ASSY (1 INCH)	65
-	-	-	-	-	-	64
-	-	1	1	983427-6	ELBOW, SWIVEL 1/8 NPT - 1/4 T	63
-	-	1	1	23238-1	QUICK DISCONNECT	62
-	-	21.00	21.00	27319-4	TUBING, POLY-FLO Ø.25	61
-	-	-	-	-	-	60
-	-	-	-	-	-	59
-	-	-	-	-	-	58
-	-	-	-	-	-	57
-	-	1	1	2-694433-9	PAWL, FEED	56
-	-	-	-	-	-	55
-	-	-	-	-	-	54
-	-	1	1	1-461062-1	FEED FINGER ASSY	53
-	-	-	-	-	-	52
-	-	-	-	-	-	51
-	-	-	-	-	-	50
-	-	-	-	-	-	49
-	-	1	1	22374-7	VALVE, QUICK EXHAUST	48
-	-	1	1	22304-1	NIPPLE, HEX 1/8 NPT	47
-	-	1	1	21004-9	SCR,SHLDR(.31 X .50)WHL ADJ	46
-	-	1	1	27058-2	BALL PLUNGER	45
-	-	1	1	1338117-1	TOOL HOLDER ASSY	44
-	-	1	1	1338124-1	WHEEL, ADJ	43
-	-	-	-	-	-	42
-	-	1	1	7-21002-7	BOLT, CRIMPER(5/16x.75)	41
-	-	-	-	-	-	40
-	-	-	-	-	-	39
-	-	-	-	-	-	38
-	-	-	-	-	-	37
-	-	-	-	-	-	36
-	-	-	-	-	-	35
-	-	-	-	-	-	34
-	-	1	1	1338397-1	PLATE, BASE	33
-	-	1	1	690432-6	SCREW, ADJUSTMENT	32
-	-	-	-	-	-	31
-	-	1	1	455689-1	BLOCK, STRIP GUIDE ADJ	30
-	-	1	1	455671-1	PLATE, STRIP GUIDE	29
-	-	1	1	455888-3	SPACER, FRONT SHEAR DEP	28
-	-	2	2	1-22284-0	SPRING, DRAG	27
-	-	1	1	690546-1	LEVER, DRAG RELEASE	26
-	-	1	1	240792-1	DRAG, TERMINAL	25
-	-	1	1	5-690440-8	GUIDE, STRIP (REAR)	24
-	-	1	1	693855-1	GUIDE, STRIP (FRONT)	23
-	-	1	1	1338200-6	SPACER, WIRE CRIMPER	22
-	-	-	-	-	-	21
-	-	1	1	1-690472-6	STRIPPER	19
-	-	-	-	-	-	18
-	-	-	-	-	-	17
-	-	-	-	-	-	16
-	-	-	-	-	-	15
-	-	-	-	-	-	14
-	-	-	-	-	-	13
-	-	1	1	5-22280-0	SPRING, SHEAR	12
-	-	1	1	690461-1	STOP, SHEAR	11
-	-	1	1	690459-1	HOLDER, SHEAR (FRONT)	10
-	-	1	1	454276-1	SHEAR, FLOAT (FRONT)	9
-	-	1	1	4-690512-8	ANVIL	8
-	-	-	-	-	-	7
-	-	-	-	-	-	6
-	-	1	1	1338126-1	DEPRESSOR, SHEAR (FRONT)	5
-	-	AR	AR	1338200-3	SPACER	4
-	-	AR	AR	1338200-2	SPACER	3
-	-	AR	AR	1338200-1	SPACER	2
-	-	1	1	1338125-5	CRIMPER, WIRE	1
-78	-77	-2	-1			

- 1 RECOMMENDED SPARE PARTS.
- 2 GREASE LIGHTLY.
- 3 GUARD MUST BE IN PLACE WHEN OPERATING APPLICATOR IN A BENCH MACHINE.
- 4 SEE DRAWING FOR COMPONENTS
- 5 ITEM NOT SHOWN
- 6 INSTALL ITEM 2,3 & 4 AS REQUIRED SHIP REMAINING ITEMS WITH APPLICATOR
- 7 CRIMPER BOLT MUST BE LOOSENED TO CHANGE CRIMP HEIGHT ADJUSTING WHEEL. BE SURE TO SEAT THE CRIMPER AGAINST THE ADJUSTING WHEEL AND REALIGN THE TOOLING.
- 8 PLACE ITEM 112 BETWEEN ITEM 71 AND 75 ON -1. PLACE ITEM 112 BETWEEN ITEM 71 AND 68 ON -2.

THIS DRAWING IS A CONTROLLED DOCUMENT.

21 FEB 2000
RELEASED FOR PUBLICATION
BY AMP INCORPORATED. ALL RIGHTS RESERVED.
© COPYRIGHT 2000

LOC A
DIST 66

QTY REQD PER ASSY PARTS LIST

DIMENSIONS IN INCHES. DO NOT SCALE PRINT. TOLERANCES UNLESS OTHERWISE SPECIFIED:
2 PLC DEC ±.25
3 PLC DEC ±.
4 PLC DEC ±.
ANGLES ±.
SURF TEXTURE: REMOVE BURRS BREAK SHARP EDGES R.015 MAX

DR SEP2399 APP SEP2399
C.ERISMAN T.ELBIN
CHK SEP2399 REL -
G.ERISMAN

TE CONNECTIVITY
Harrisburg, PA 17105-3608

NAME SIDE FEED THRU SPLICE APPLICATOR MACHINE REF THRU-G

SCALE DWG No 566392 SHEET 1 of 1 REV G

00779 CUSTOMER AND ASSEMBLY DRAWING 1 RESTRICTED TO