

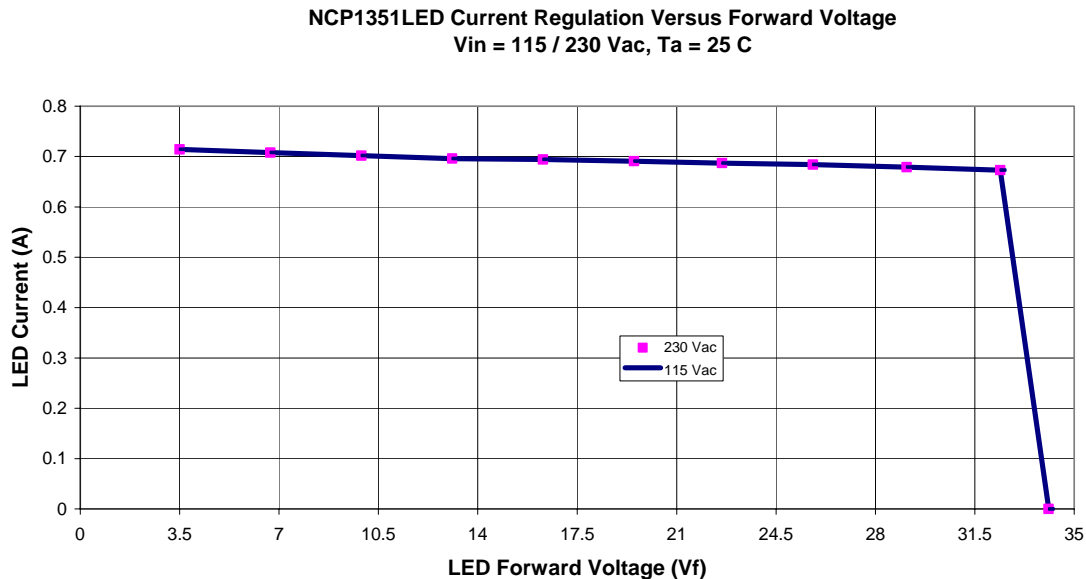

Test Procedure for the NCP1351LEDEVB Driver Evaluation Board

Introduction:

The NCP1351 LED Driver Board is a universal input, off-line power supply intended to provide a constant current output with a maximum “header” voltage for powering strings of LEDs. The output has a constant current, constant voltage profile. While the user can adjusted the output current and maximum voltage by changing a few discrete components, as shipped the board is designed to provide a nominal output current of 700mA and has a maximum voltage of 34 Vdc. A typical curve of the current regulation versus output voltage is illustrated below.



Test Equipment Required:

1. Adjustable, isolated AC power source capable of zero to 265 Vac output and up to 500 mA. AC source should have the capability of measuring output power in watts. If not, an AC line analyzer or AC wattmeter should be used. Wattmeter should be capable if reading down to 50 mW (for standby power measurements.)
2. Digital volt/amp meters to measure output current and voltage to the electronic load.
3. A variable electronic load or rheostat capable of up to a 2 amp load at 40 volts. If an electronic load is used it is preferable to have it operate in a constant resistance load mode.
4. Oscilloscope with probe to monitor output ripple on the demo converter.



Setup Procedure:

Set the equipment as shown in the diagram on the next page so that the output voltage and current to the demo board can be measured. The oscilloscope should be set up so that the output ripple can be monitored.

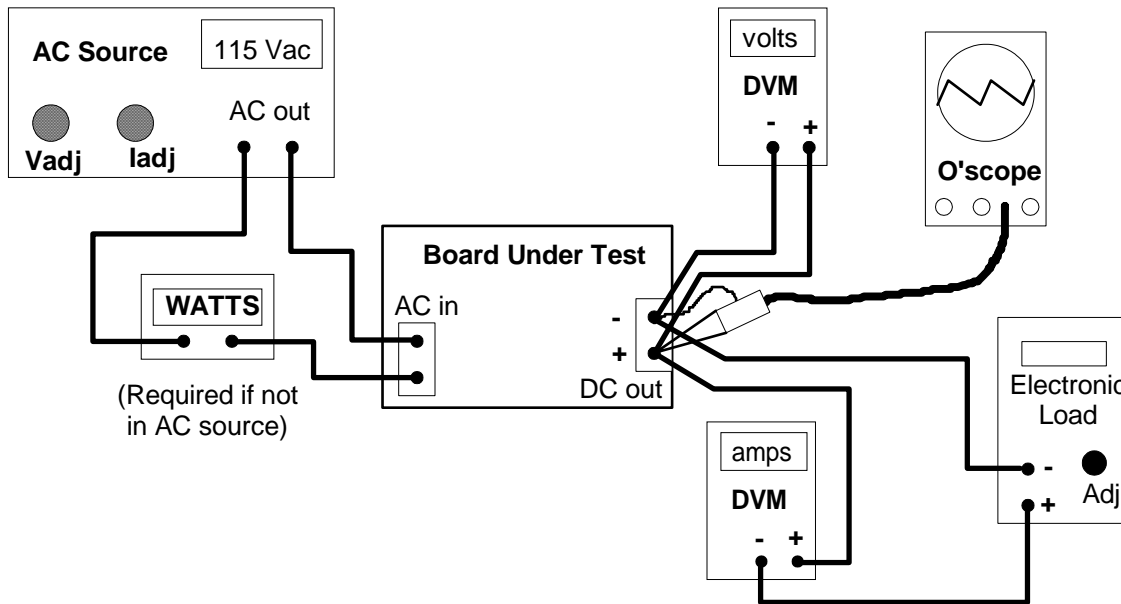

Test Procedure:

1. Switch the electronic load on, set to constant resistance mode and the load adjust to zero load; switch all of the digital meters on (assuming they are wired properly for voltage and current sensing); turn the oscilloscope on with sensing in AC mode and 200 mV per division vertical and a sweep rate of 5 uS per division. Connect the scope probe to the demo board's output terminals.
2. With the AC source OFF, set the current limit on the AC source to 1 A and the output voltage to 115 Vac.
3. Turn on the AC source and the power supply demo board output voltage should be the rated output voltage $34 +1$ volt/ $- 1$ volts on the DVM.
4. Adjust the electronic load from no load slowly up to the rated output current. The output voltage should remain within 700 ± 50 mA. The output ripple on the oscilloscope should be less than 500 mV peak-to-peak.
5. Reduce the AC input to 90 Vac and make sure the conditions of test 4 above still hold.
6. Return the input to 115 Vac and continue to increase the load slowly and the current should remain constant within 700 ± 50 mA as voltage collapses (constant current output.)
7. Set the electronic load to back to zero and the output voltage should return to the rated level.
8. Check the AC input power. It should be below 400 mW.



9. Adjust the AC input to 230 Vac and repeat tests (3) through (7).
10. Set the electronic load to zero and switch the AC source off.

End of Test.