

PROPER USE GUIDELINES

Cumulative Trauma Disorders can result from the prolonged use of manually powered hand tools. Hand tools are intended for occasional use in low volume applications. A wide selection of powered application equipment for extended-use, production operations is available.

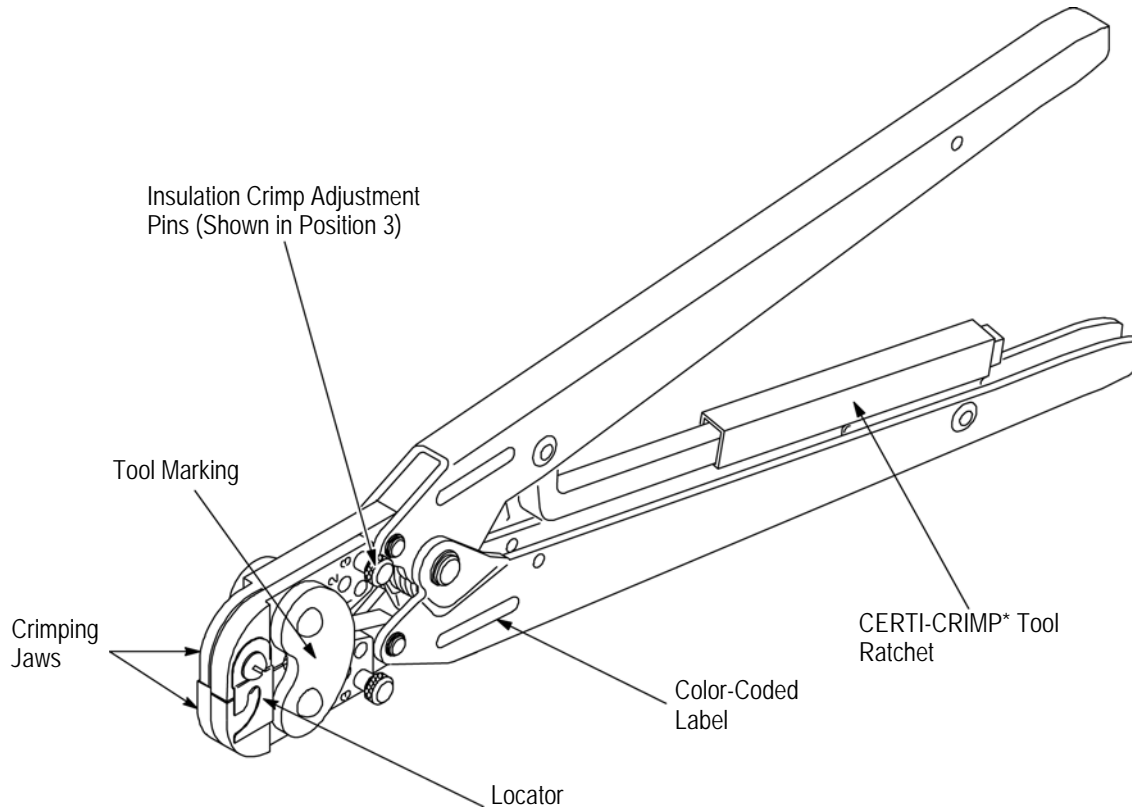



Figure 1

1. INTRODUCTION

TE Connectivity Hand Crimping Tools 45160 and 45575-1 (shown in Figure 1) are used to crimp PLASTI-GRIP* butt splices (listed in Figure 2) onto stranded or solid wire sizes 22 through 14 AWG.

NOTE  Dimensions in this instruction sheet are in millimeters [with inches in brackets]. Figures and illustrations are for reference only and are not drawn to scale.

Reasons for reissue of this instruction sheet are provided in Section 7, REVISION SUMMARY.

2. DESCRIPTION (Figure 1)

Each hand tool consists of two crimping jaws, locator, two insulation crimp adjustment pins, and a CERTI-CRIMP tool ratchet. The FRONT of the tool, into which the splice is inserted, has the TE logo marked on the link. The tool handles have color-coded labels which match the insulation color of the splices and correspond with a given wire size range.

The locator positions the splice between the crimping jaws. The insulation crimp adjustment pins are used to regulate the crimp height of the splice insulation barrel sleeve. The ratchet assures full crimping of the splice. Once engaged, the ratchet will not release until the tool handles have been FULLY closed.

CAUTION  The crimping jaws bottom before the CERTI-CRIMP tool ratchet releases. This feature ensures maximum electrical and tensile performance of the crimp. Do NOT re-adjust the ratchet.

3. CRIMPING PROCEDURE

NOTE  Each hand tool is coated with a preservative to prevent rust or corrosion. Wipe this preservative from the tool, particularly from the crimping jaws, before using the tool.

Refer to Figure 2 to make sure that the splice, wire size, and tool are compatible.



Similar splices with an insulation color other than red or blue can be crimped with these tools; however, wire size must be used, instead of the tool-to-product color code, to establish compatibility.

Typical PLASTI-GRIP Butt Splice

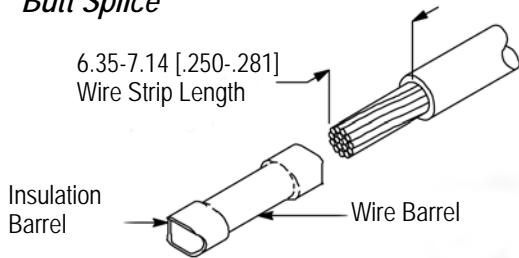

Wire Size Range (AWG)	Splice	Color Code (Splice and Tool)	Tool
22-16	34203	Red	45160
	34067		
	34070		
	34178		
	34243		
	55792-1 324138		
16-14	34204	Blue	45575-1
	34068		
	34071		
	2-34071-2		
	8-34071-1		
	8-34071-4		
	8-34071-5		
	35244		
	328427		
	8-328427-1 55785-1		

Figure 2



A complete list of butt splice part numbers cannot be maintained on this document. For all part numbers and their description, refer to your TE Representative.

Proceed as follows:

- Strip the wire using the appropriate strip length dimensions provided in Figure 2. Do NOT nick or cut the wire strands.
- Open the crimping jaws by squeezing the tool handles together until the ratchet releases.
- Insert stripped wire into the splice wire barrel.
- Locate the splice—with the wire inserted—into the crimping jaws, as shown in Figure 3. The end of the splice should rest against the locator.

Crimping Butt Splice

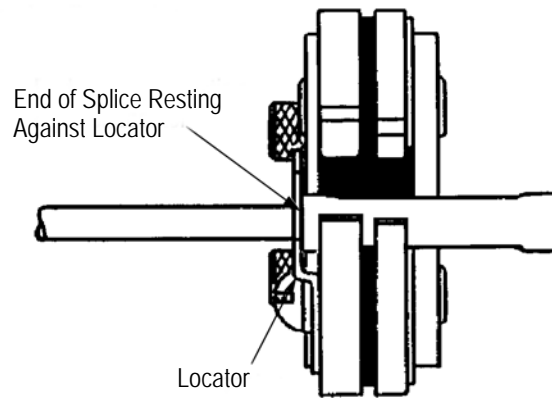
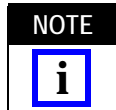
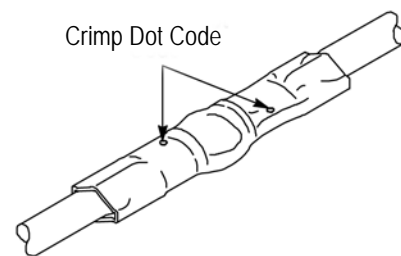

Figure 3

- Hold wire in place and squeeze tool handles together until the CERTI-CRIMP tool ratchet releases. Allow tool handles to open FULLY. Remove the crimped splice from the tool.
- To crimp other half of splice, position the uncrimped wire barrel in the tool, and crimp as described in Step 5.
- Remove the crimped splice from the tool, and inspect the crimp. Make sure the proper crimp dot code is shown on the splice insulation for the appropriate hand tool. Refer to Figure 4.



For detailed crimp inspection requirements, refer to Application Specification 114-2161.



Tool	Color Code	Crimp Dot Code
45160	Red	1 Dot
45575-1	Blue	2 Dots

Figure 4

4. INSULATION CRIMP ADJUSTMENT

Each tool has three insulation crimp adjustment positions to adjust the wire insulation grip: 1—Tight, 2—Medium, and 3—Loose. To obtain the desired insulation grip, proceed as follows:

1. Insert pins into Position 3.



Both pins must be inserted into the same adjustment position.

2. Position splice into crimping jaws, as described in Section 3, Step 4.
3. Insert an UNSTRIPPED wire into just the splice insulation barrel.
4. Crimp the splice using the procedure described in Section 3, Step 5. Remove the crimped splice from the crimping jaws, and check the insulation support by bending the wire back and forth once.

The insulation barrel should retain grip on the wire insulation. If the wire pulls out, move the insulation crimp adjustment pins to the next tighter position (Position 2) then proceed to Step 5. If the wire does not pull out, the pins are properly adjusted. NOTE: Do NOT use a tighter setting than is required.

5. Perform another test crimp. Adjust pins, as necessary, until the desired insulation grip is obtained.

5. MAINTENANCE AND INSPECTION

TE recommends that a maintenance and inspection program be performed periodically to ensure dependable and uniform terminations. Frequency of inspection depends on:

1. The care, amount of use, and handling of the hand tool;
2. The presence of abnormal amounts of dust and dirt;
3. The degree of operator skill; and
4. Your own established standards.

The tool is inspected before being shipped from the plant; however, TE recommends that the tool be inspected immediately upon arrival at your facility to ensure that the tool has not been damaged during shipment.

5.1. Daily Maintenance

1. Remove dust, moisture, and other contaminants with a clean brush, or a soft, lint-free cloth. Do NOT use objects that could damage the tool.
2. Make certain that the retaining pins are in place and that they are secured with retaining rings.

3. All pins, pivot points, and bearing surfaces should be protected with a thin coat of any good SAE‡ 20 motor oil. Do NOT oil excessively.

4. When the tool is not in use, keep handles closed to prevent objects from becoming lodged in the crimping jaws. Store the tool in a clean, dry area.

5.2. Lubrication

Lubricate all pins, pivot points, and bearing surfaces with SAE 20 motor oil as follows:

- Tools used in daily production—lubricate daily
- Tools used daily (occasional)—lubricate weekly
- Tools used weekly—lubricate monthly

Wipe excess oil from tool, particularly from crimping area. Oil transferred from the crimping area onto certain terminations may affect the electrical characteristics of an application.

5.3. Periodic Inspection

1. Hand tool should be immersed (handles partially closed) in a reliable commercial degreasing compound to remove accumulated dirt, grease, and foreign matter.
2. Close tool handles until ratchet releases and then allow them to open freely. If they do not open quickly and fully, the spring is defective and must be replaced. See Section 6, REPLACEMENT AND REPAIR.
3. Inspect head assembly for worn, cracked, or broken jaws. If damage is evident, refer to Section 6, REPLACEMENT AND REPAIR, for customer repair service.

5.4. Gaging the Crimping Chamber

This inspection requires the use of a plug gage conforming to the dimensions provided in Figure 5. TE does not manufacture or market these gages.

To gage the crimping chamber, proceed as follows:

1. Remove traces of oil or dirt from the crimping chamber and plug gages.
2. Align the GO element of the wire barrel crimp plug gage with the wire barrel section of the crimping chamber. Push element straight into the crimping chamber without using force. The GO element must pass completely through the crimping chamber, as shown in Figure 6, Detail A.
3. Align the NO-GO element and try to insert it straight into the same crimping chamber. The NO--GO element may start entry, but must not pass completely through the crimping chamber. See Figure 6, Detail A.

‡ Society of Automotive Engineers is a trademark of SAE International Corporation.

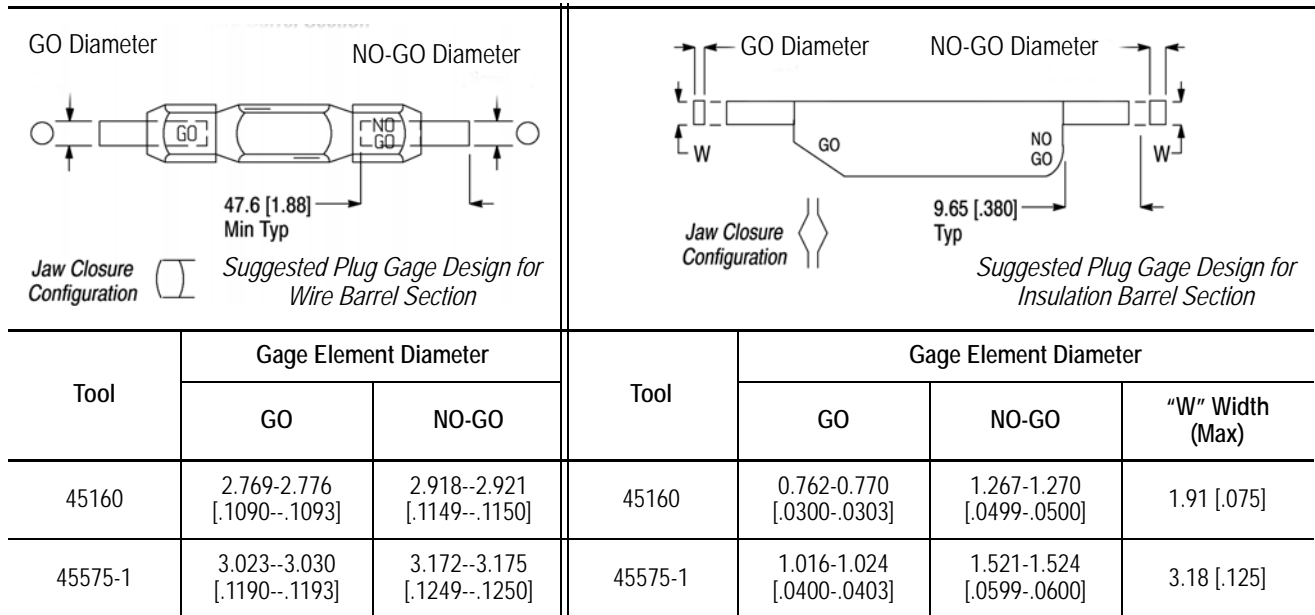
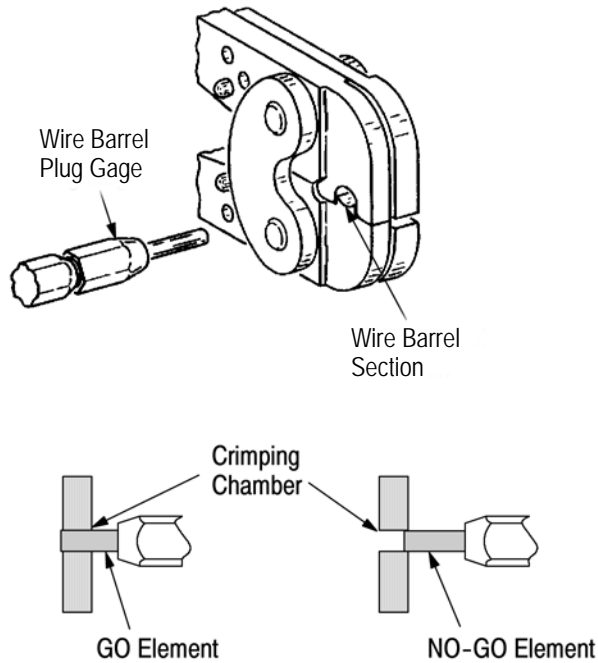

Figure 5

Inspection of Crimping Chamber

Detail A



GO element must pass completely through the crimping chamber.

NO-GO element may enter partially, but must NOT pass completely through the crimping chamber.

Detail B

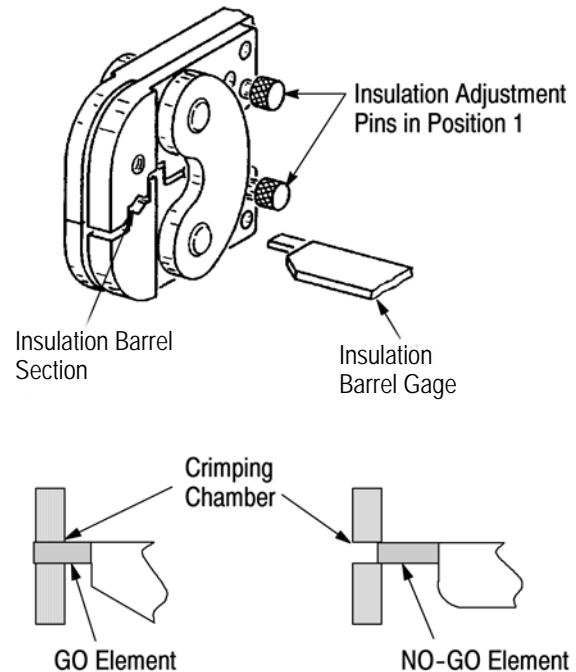

GO element must pass completely through the crimping chamber.

NO-GO element may enter partially, but must NOT pass completely through the crimping chamber.

Figure 6

4. Insert insulation crimp adjustment pins into Position 1.
5. Check the insulation barrel section of the crimping chamber using the insulation crimp plug gage in the same manner as in Steps 2 and 3. See Figure 6, Detail B.

If the crimping chamber conforms to the gage inspection, the tool is considered dimensionally correct, and should be lubricated with a THIN coat of any good SAE 20 motor oil. If not, refer to Section 6, REPLACEMENT AND REPAIR for obtaining further evaluation and repair.

For additional information regarding the use of plug gages, refer to Instruction Sheet 408-7424.

5.5. CERTI-CRIMP Tool Ratchet Inspection

The CERTI-CRIMP tool ratchet should be checked to ensure that the ratchet does not release prematurely, allowing the jaws to open before they have fully bottomed. Obtain a 0.025 mm [.001 in.] shim that is suitable for checking the clearance between the bottoming surfaces of the crimping jaws. Proceed as follows:

1. Select a splice and *maximum* size wire for the tool.
2. Position the splice and wire in tool as described in Section 3, CRIMPING PROCEDURE.
3. Hold the wire in place and squeeze the handles until the ratchet releases. Hold the handles in this position, maintaining just enough tension to keep the jaws closed.

4. Close the tool handles until it is evident that the jaws have bottomed; then hold in this position. Do NOT force the jaws beyond initial contact.

5. Check the clearance between the bottoming surfaces of the crimping jaws. If the clearance is 0.025 mm [.001 in.] or less, the ratchet is satisfactory. If clearance exceeds 0.025 mm [.001 in.], the ratchet is out of adjustment and must be repaired. See Section 6, REPLACEMENT AND REPAIR.

6. REPLACEMENT AND REPAIR

Customer-replaceable parts are listed in Figure 7. A complete inventory should be stocked and controlled to prevent lost time when replacement of parts is necessary. Parts other than those listed should be replaced by TE to ensure quality and reliability. Order replacement parts through your TE Representative, or call 1-800-526-5142, or send a facsimile of your purchase order to 717-986-7605, or write to:

CUSTOMER SERVICE (038-035)
TYCO ELECTRONICS CORPORATION
PO BOX 3608
HARRISBURG PA 17105-3608

For customer repair service, please contact a TE Representative at 1-800-526-5136.

7. REVISION SUMMARY

Revisions to this instruction sheet include:

- Corrected dimension in table in Figure 5

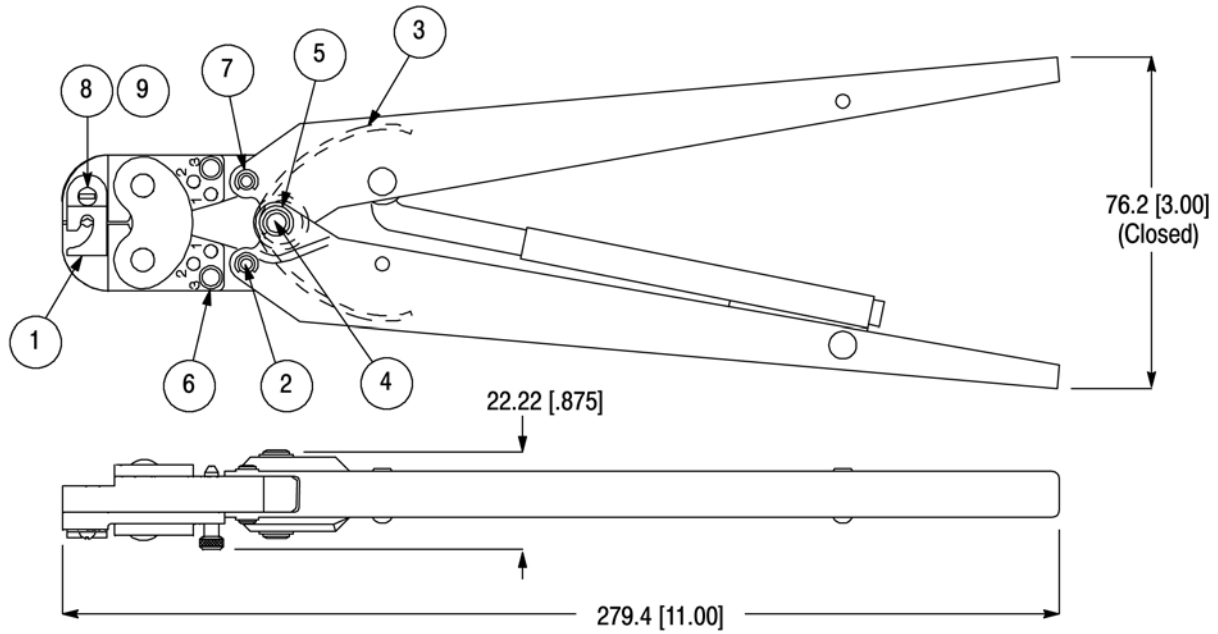

REPLACEMENT PARTS

Item	Part Number	Description	Qty Per Tool
1	305173	LOCATOR (Stop) -- Tool 45160 Only	1
1	305234	LOCATOR (Stop) -- Tool 45575-1 Only	1
2	8-59558-2	PIN, Retaining	2
3	39364	SPRING, Hold Down	1
4	2-23620-9	PIN, Straight, Grooved	1
5	21045-6	RING, Retaining	2
6	39207	PIN, Crimp Adjustment	2
7	21045-3	RING, Retaining	4
8	24367-4	WASHER, Spring Lock	1
9	4-21924-4	SCREW, Machine	1

Figure 7