

1 FIGURE OF INSERTION

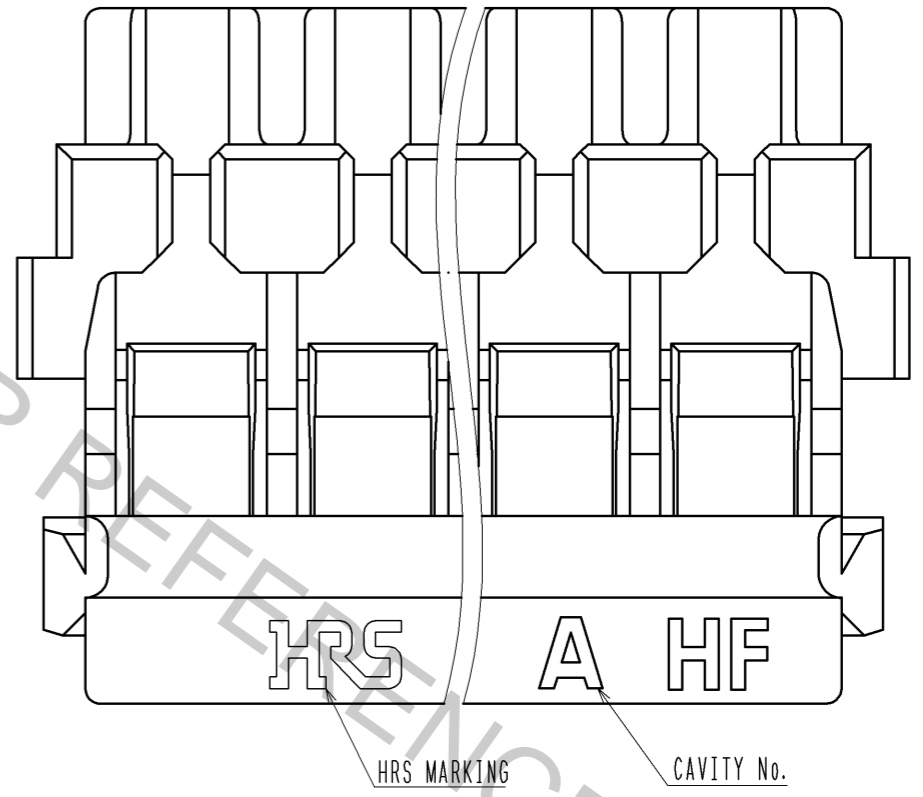
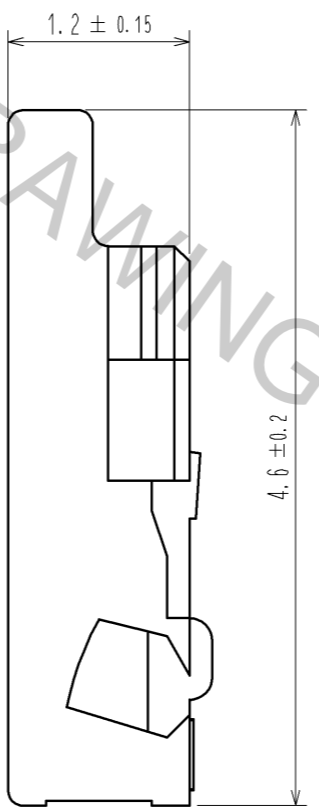
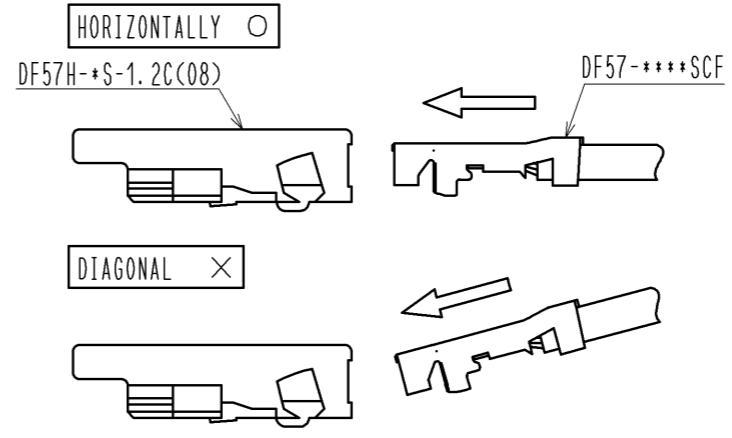

NOTE 1 AVOID ANGLED INSERTION OF CRIMP CONTACT(DF57-****SCF) TO MAINTAIN PERFORMANCE RELIABILITY.

CODE No.	PART No.	NUMBER OF CONTACTS	A	B	C	D	D
CL666-0100-6-08	DF57H-2S-1.2C(O8)	2	1.2	3.5	2.98	2.6	3.15
CL666-0012-0-08	DF57H-3S-1.2C(O8)	3	2.4	4.7	4.18	3.8	4.35
△ CL666-0101-9-08	DF57H-4S-1.2C(O8)	4	3.6	5.9	5.38	5.0	5.55
△ CL666-0102-1-08	DF57H-5S-1.2C(O8)	5	4.8	7.1	6.58	6.2	6.75
△ CL666-0103-4-08	DF57H-6S-1.2C(O8)	6	6.0	8.3	7.78	7.4	7.95

UNITS mm		SCALE 20:1		△の数 2		訂正記事 DIS-H-008103		設計 TS. KUMAZAWA		検図 HK. UMEHARA		年月日 13.08.19	
HRS HIROSE ELECTRIC CO., LTD.		承認: KI. AKIYAMA 12.11.21		検図: HK. UMEHARA 12.11.21		設計: TS. KUMAZAWA 12.11.21		製図: TS. KUMAZAWA 12.11.21		部番 1 LCP		UL94V-0. NATURAL(BEIGE)	
		材質		処理, 備考		部番		材質		処理, 備考		訂正記事	
												製品名: DF57H-*S-1.2C(O8)	
												製品コード CL666-	

DF57 Series Mating / Unmating Operation Instruction

Mating

① By positioning the convexity of the socket sides to the header concavity, align the centers of the socket and the header in pitch direction.

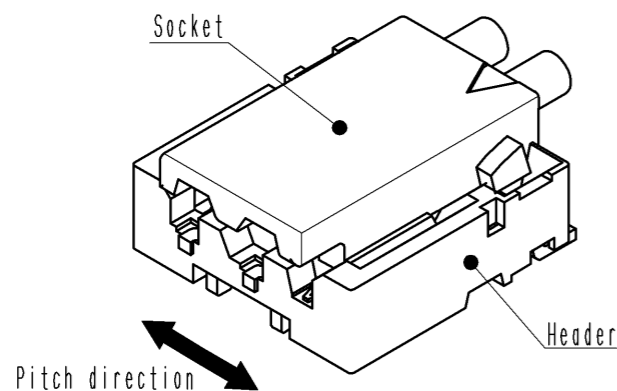

② Slightly press the socket down at cable side to tilted angle.

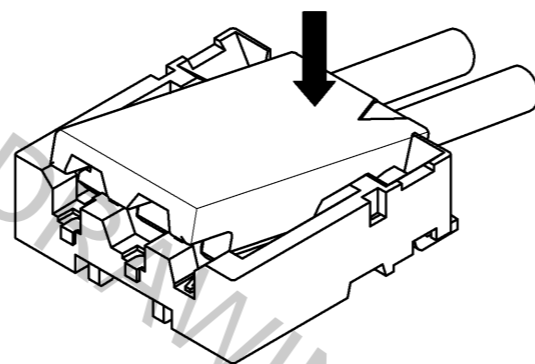

③ Press down at the lever side with stabilizing the cable side to insert. Mating completes.

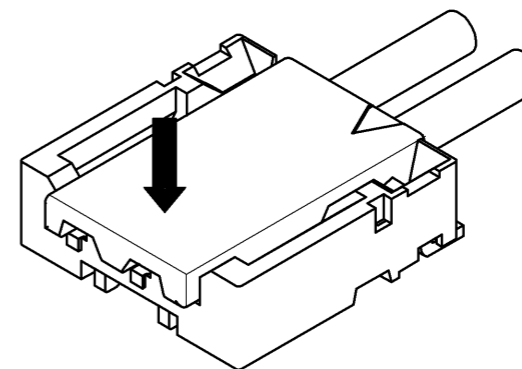

Unmating

① Hook the lever with finger nail.

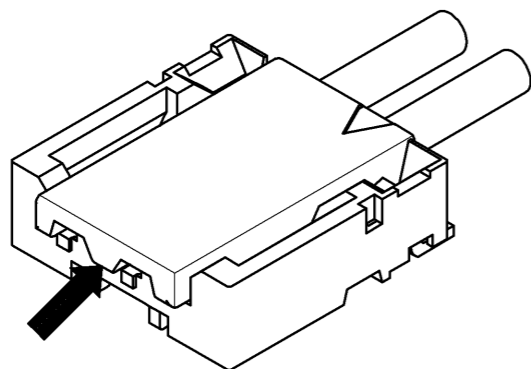

② Lift up to the upper direction and friction lock is released.

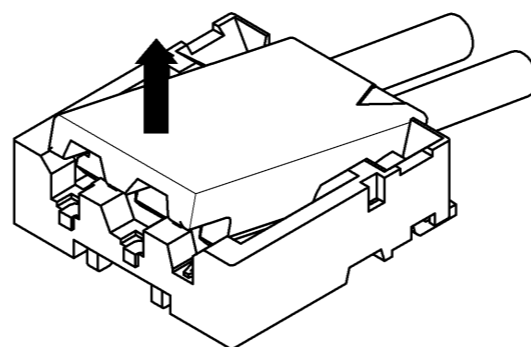

③ Lift up to the upper direction and positive lock is released. Removal completes.

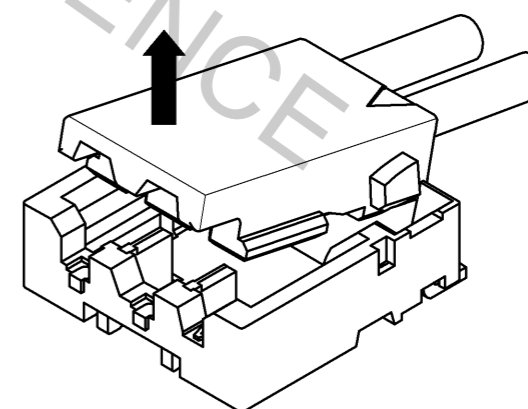

HRS	DRAWING NO.	EDC3-349275-01
	PART NO.	DF57H-*S-1.2C<08>
	CODE NO.	CL666-
		1/2