

**3M**

4320 SS-25

Self-Strip Terminating Block

Instructions

## 1.0 General

The 3M™ 4320 SS-25 Self-Strip Terminating Block is a factory stubbed, self-stripping connecting block designed for 22- (0.6 mm) and 24-gauge (0.5 mm) jumper wire. The self-strip caps automatically connect and trim the jumper wire with a 90° turn of the cap. The 4320 Blocks are dimensionally compatible with all pedestal and pole-mount cabinets used in the 3M 4310 Modular Hardwire System.

*Note: White 4320 SS-25 Self-Strip Terminating Blocks are intended for use in OSP (Outside Plant) applications only, mounted in OSP pedestal or pole-mount cross-connect cabinets. Grey blocks are intended for indoor use, on the equipment side of a primary telephone protector.*

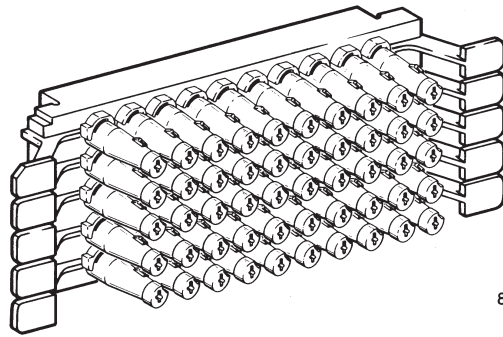

842959

**4320 SS-25 Self-Strip Terminating Block**

## 2.0 Accessories

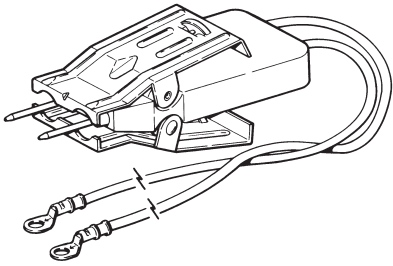

843003

**4327 Single Pair Probe**

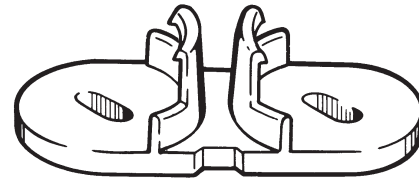
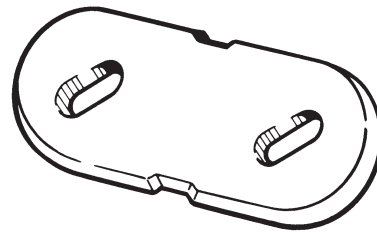

842978

**4324 SS Priority Cap**

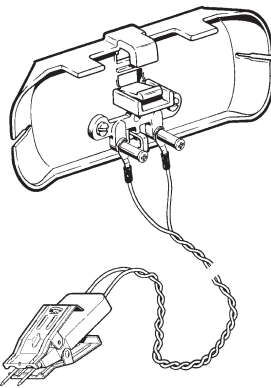

**4327-A Probe and Dish**

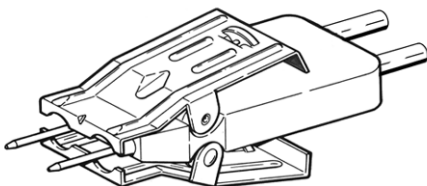

**4327P Pocket Probe**

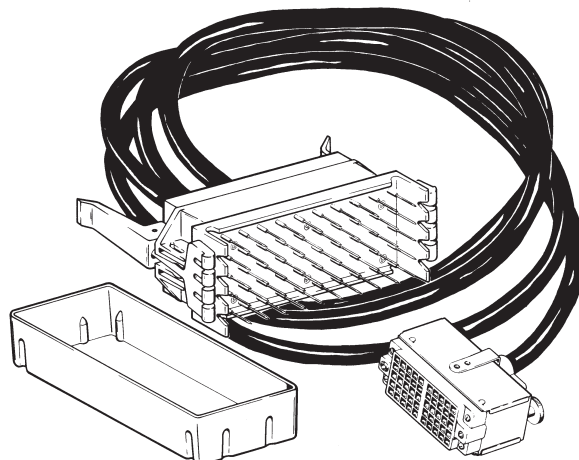

842960

**4328 SS 25 Pair Test Connector**

### 3.0 Running Jumper Wires

- 3.01 Pull 24 AWG (0.5 mm) or 22 AWG (0.6 mm) jumper wire from spool to feeder block. (Green labels on tabs.)
- 3.02 Split pair (TIP-left, RING-right) at the assigned cap position.

**Note:** Wire ends should not be stripped.

- 3.03 Form 90° hook on end of jumper wire as shown. Make sure wires have cleanly-cut ends.

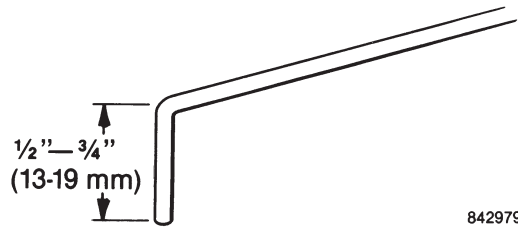

- 3.04 Make sure assigned caps are in the preinsertion position with the screwdriver slot oriented vertically.

Screwdriver Slot                      Entry Port

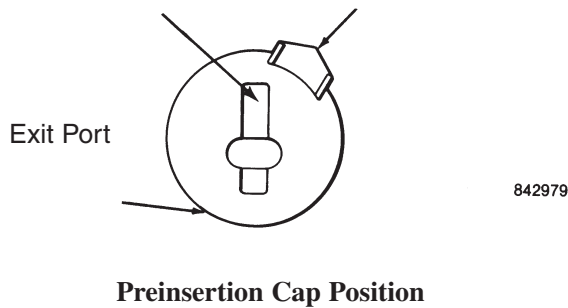

- 3.05 Insert wire into entry port and through the cap until the wire is visible from the exit port.

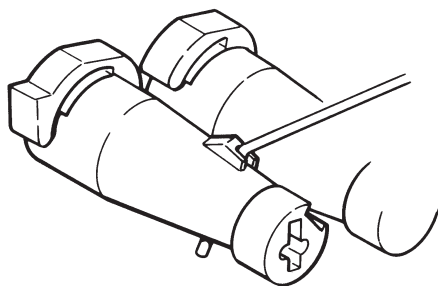

- 3.06 Insert screwdriver in cap slot and rotate 90° clockwise until you *feel* the cap come to rest against the stop. As the cap rotates, the wire is simultaneously connected and trimmed off.

**Note:** Make sure screwdriver blade is fully inserted into cap slot before rotating.

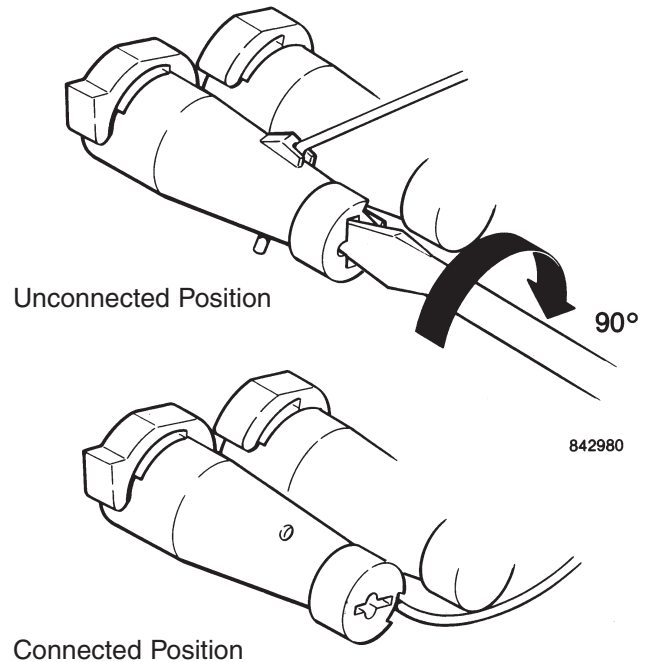

- 3.07 Always route jumper wires *below* the connected cap.

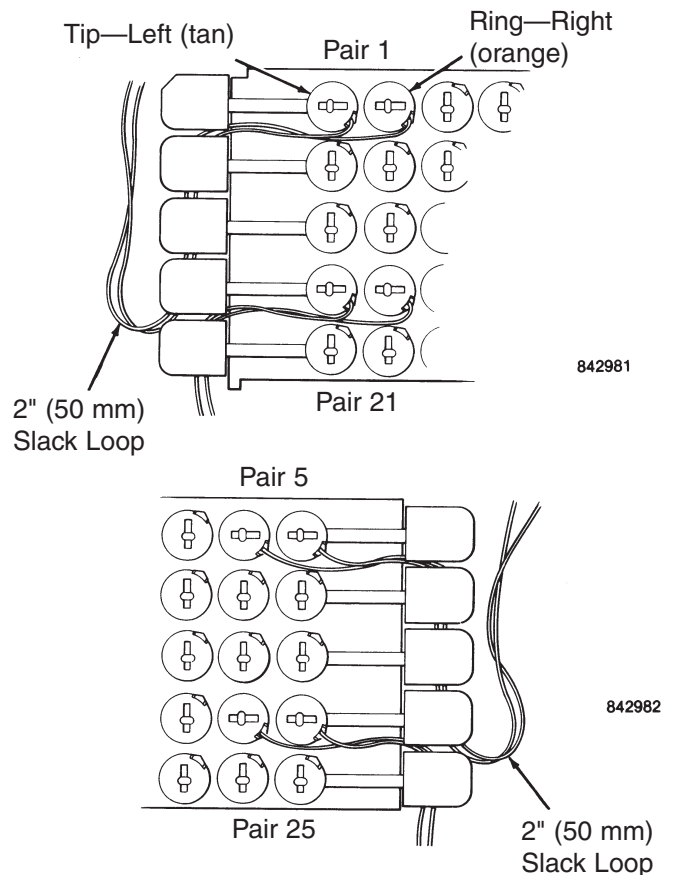

3.08 Lay jumper wires into runway between self-strip caps. Push the jumpers down into the runway below the connection ports.

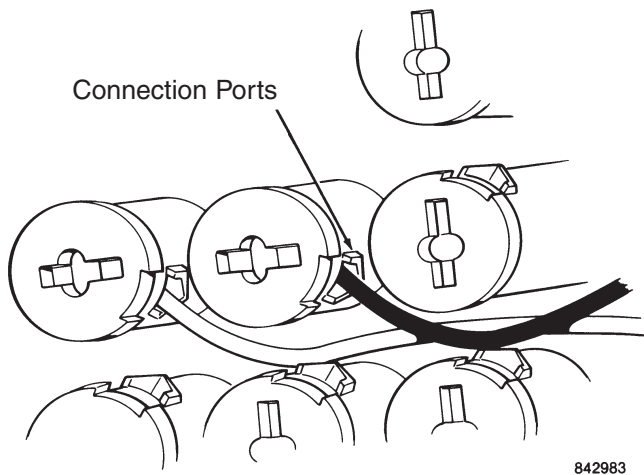

3.09 Route jumper wires to assigned distribution block and pair. Cut wires to a length allowing 2" (50 mm) of slack. Form jumper wires and insert per Sections 3.03 through 3.06.

3.10 Again route jumper wires into channel *below* the connected caps and form a slack loop in the jumper channel.

3.11 **Removing jumper wire:** Rotate cap 90° counter-clockwise until you *feel* the cap come to rest against the stop. Remove jumper wire from port. The cap is now ready to accept a new jumper wire.

**Note:** *If reinserting the same jumper wire, cut the wire end before insertion to avoid the original point of connection.*

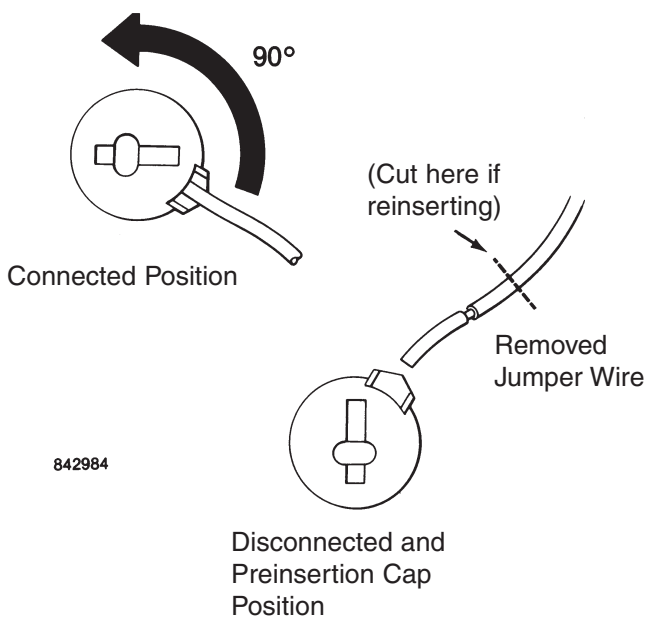

## 4.0 Accessory Usage

### 4.01 3M™ 4324 SS Priority Circuit Caps

4324 SS Caps are available to designate and isolate priority circuits. The holes in the cap permit partial insertion but *no* electrical contact when using either the 4328 SS 25 Test Connector or the 4327 SS Pair Probe.

- a. Insert extended legs between tip and ring caps until they snap under the cap head. One priority cap covers a full pair.

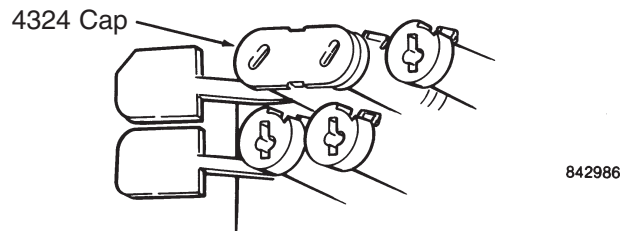
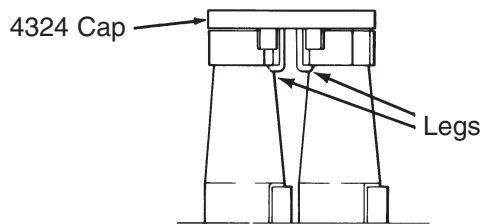

### 4.02 3M™ 4327 SS Pair Probe

The 4327 SS Pair Probe provides electrical access to a pair of 4320 self-strip contacts.

- a. Align pair probe as shown.

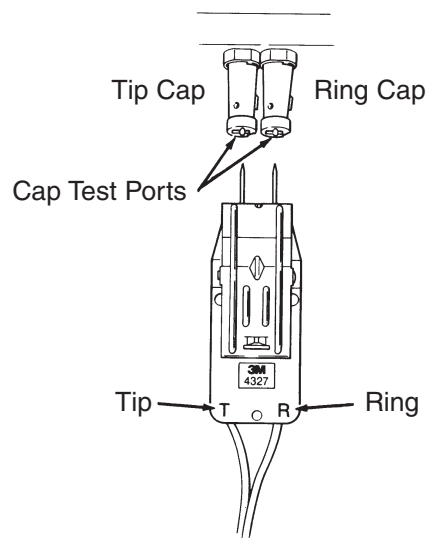

**Note:** *Pair probe attaches to connected or unconnected caps.*

- b. Insert pins in test ports. Depress spring-loaded clamps sufficiently to allow clearance over cap heads.

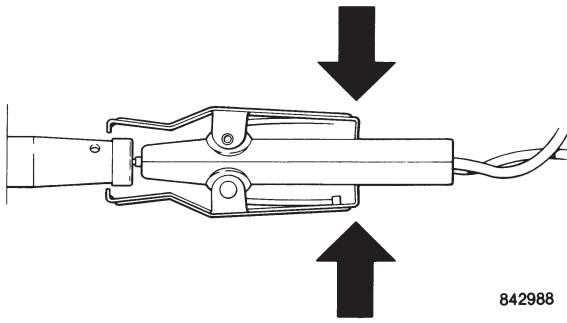

Release and position fingers behind clamps. Push pair probe forward until the clamps snap behind the cap heads.

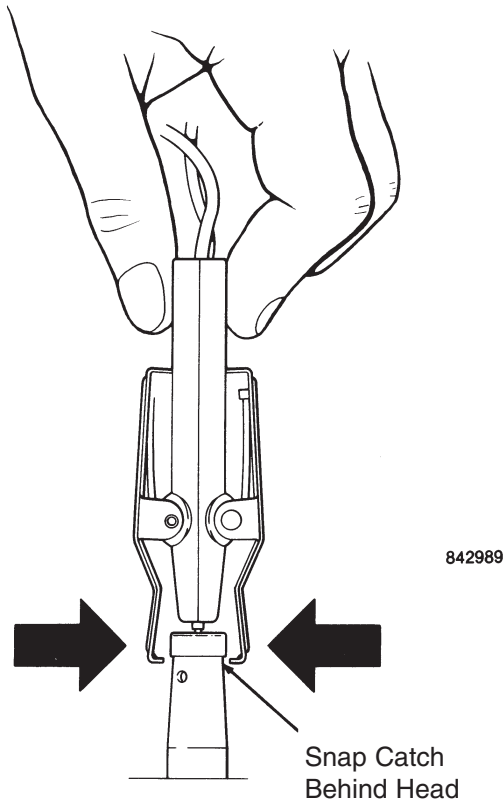

**Note:** 4324 Priority Caps prevent unauthorized (test probe) access.

- c. Remove probe by depressing clamps clear of the cap head and pulling pair probe clear of the caps.

#### 4.03 3M™ 4328 SS 25-Pair Test Connector

The 4328 25-Pair Test Connector provides access for test equipment to the 3M™ 4320 SS-25 Terminating Block. The test connector connects to test equipment with a female cinch-type connector.

##### Attaching the Test Connector

- a. Remove the plastic connector cover.
- b. Holding the test connector around the rear cord strain relief, swing the handles out and push clamps to forward position.

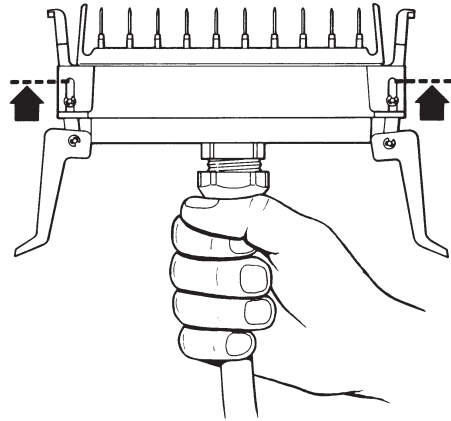

- c. Align the test connector in front of the block to be tested. Make sure the test connector is right side up (label side up). Push in the test connector to compress the test pins against the elements in the caps. Slide the extended clamps under and against the inside of the block tabs.

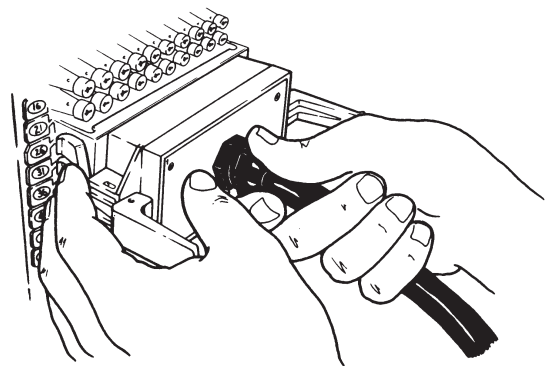

**Note:** 4324 Priority Caps allow the self-strip block to be tested with the test connector, making connection to all circuits except those with priority caps in place. The holes in the cap permit partial insertion (no electrical contact) into special circuit ports.

- d. Swing in the handles to lock the test connector in contact with the block.

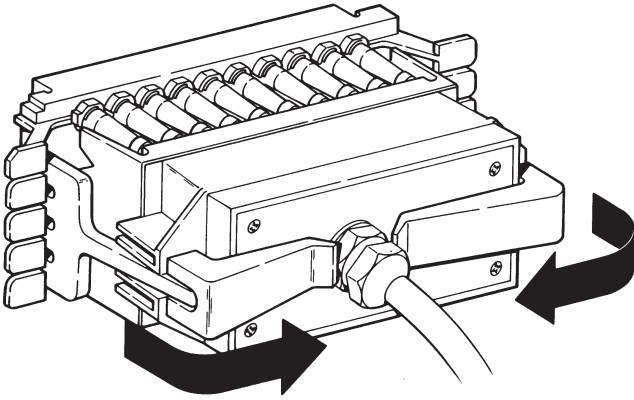

842991

- e. Attach the test connector to test equipment and test block per standard procedure.

### Removing the Test Connector

- a. Swing handles out and apply pressure at the sides of the base of each clamp. This will detach the clamps from the block tabs.

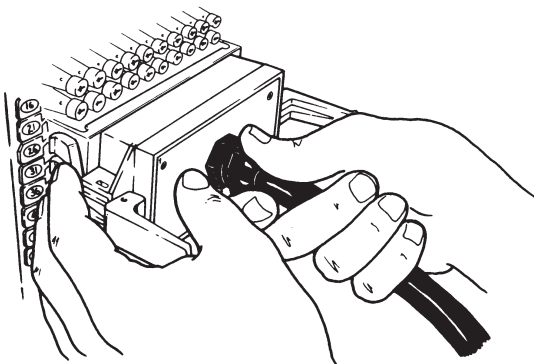

842962

**Notes:**

3M is a trademark of 3M Company.

**Important Notice**

Before using this product, you must evaluate it and determine if it is suitable for your intended application. You assume all risks and liability associated with such use.

**Warranty; Limited Remedy; Limited Liability.** This product will be free from defects in material and manufacture as of the date of purchase. **3M MAKES NO OTHER WARRANTIES INCLUDING, BUT NOT LIMITED TO, ANY IMPLIED WARRANTY OF MERCHANTABILITY OR FITNESS FOR A PARTICULAR PURPOSE.** If this product is defective within the warranty period stated above, your exclusive remedy shall be, at 3M's option, to replace or repair the 3M product or refund the purchase price of the 3M product. **Except where prohibited by law, 3M will not be liable for any loss or damage arising from this 3M product, whether direct, indirect, special, incidental or consequential regardless of the legal theory asserted.**

**3M**

Telecom Access Division

3M Telecommunications

6801 River Place Blvd.

Austin, TX 78726-9000

[www.3M.com/telecom](http://www.3M.com/telecom)