

THIS DRAWING IS UNPUBLISHED. RELEASED FOR PUBLICATION  
 © COPYRIGHT BY TYCO ELECTRONICS CORPORATION. ALL RIGHTS RESERVED.

LOC	DIST	REVISIONS			
P	LTR	DESCRIPTION	DATE	DWN	APVD
AG	53	0	RELEASED	25JAN06	JDP JGH

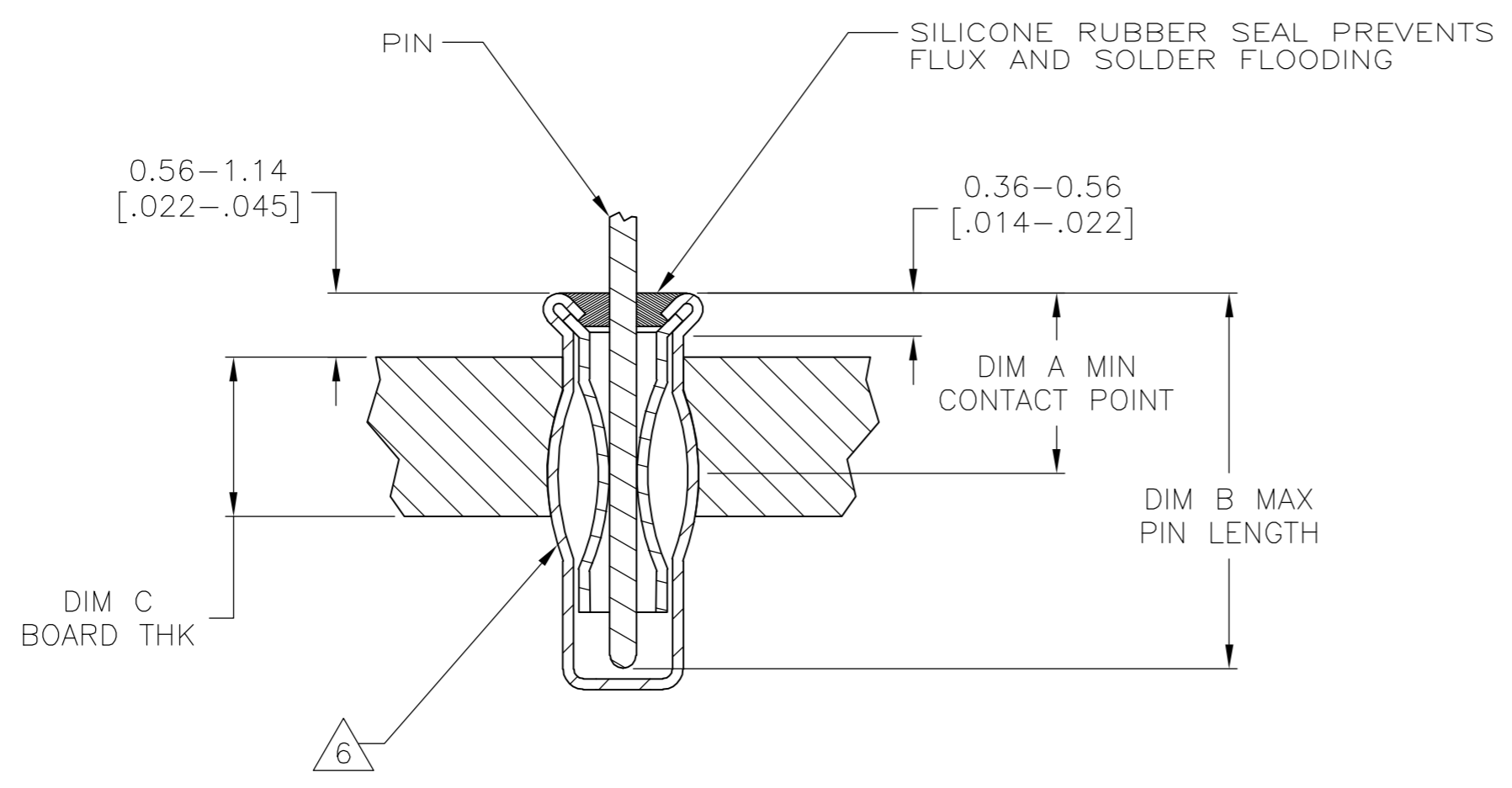
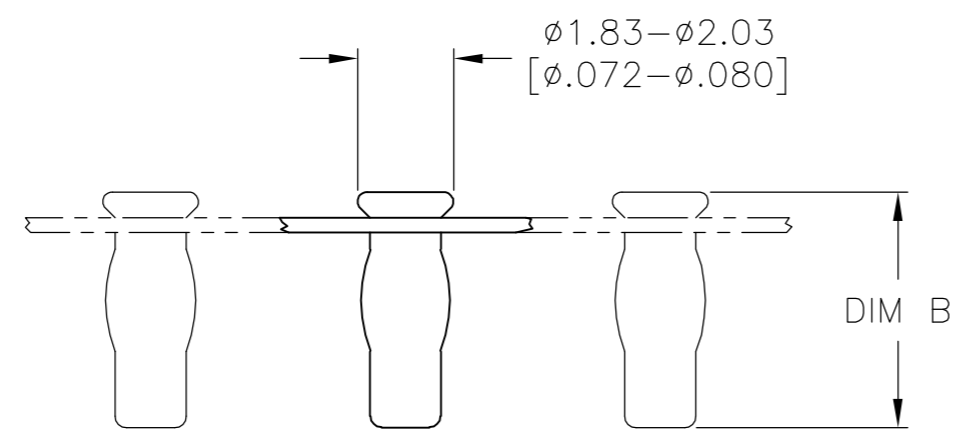
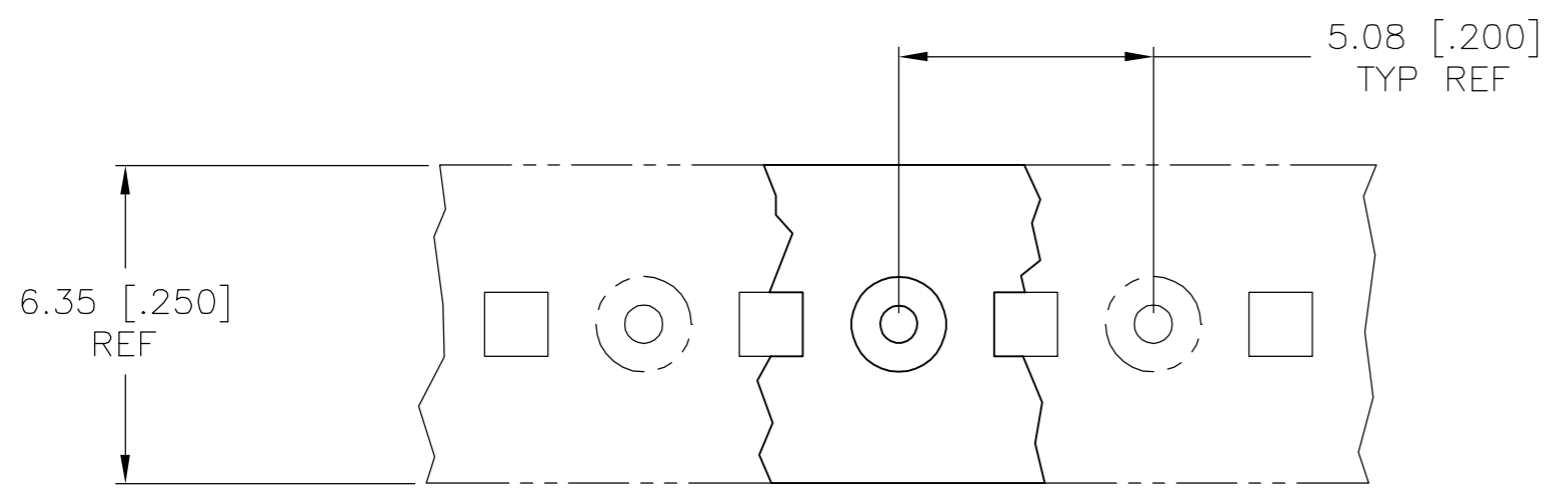

- 1 MATERIAL:  
 EYELET - COPPER PER ASTM B 152  
 SPRING - BERYLLIUM COPPER PER ASTM B 194  
 SEALANT - SILICONE RUBBER
- 2 TIN PLATE PER ASTM B 545, 0.00254 [.000100] MINIMUM THICKNESS.
- 3 GOLD PLATE PER ASTM B 488, 0.00076 [.000030] MIN THK ON CONTACT AREA.
- 4 PACKAGED, 10,000 PER REEL.
- 5 TO INSURE 1/2 OZ MIN RETENTION DO NOT EXCEED 0.05 [.002] DIFFERENCE IN PIN DIA WHEN CHANGING TO A SMALLER DIA PIN
- 6 PRODUCT IS OVALIZED FOR RETENTION IN THE P.C. BOARD. THE RECOMMENDED HOLE DIAMETER IS  $\phi 1.57$  [ $\phi 0.062$ ] MINIMUM, +0.08 [.003] MAX. PRIOR TO SOLDERING.

0.79-3.18 [.031-.125]	6.53 [.257]	3.56-6.32 [.140-.249]	$\phi 0.66 - \phi 0.84$ [ $\phi 0.026 - \phi 0.033$ ]	GOLD 3	TIN 2	5645994-1
DIM C	DIM B	LENGTH	DIM A DIA	5	SPRINGEYELET	PART NO
				FINISH		

THIS DRAWING IS A CONTROLLED DOCUMENT.		DWN J. POLIGNONE 25JAN06	Tyco Electronics Corporation Harrisburg, PA 17105-3608	
DIMENSIONS: mm [INCHES]		CHK J. HAVENER 25JAN06	NAME MINIATURE SPRING SOCKET ASSY SERIES 3 WITH SEALANT	
TOLERANCES UNLESS OTHERWISE SPECIFIED:		APVD J. HAVENER 25JAN06	DRAWING NO 114-26004	
0 PLC ± - 1 PLC ± - 2 PLC ± - 3 PLC ± 0.20[.008] 4 PLC ± - ANGLES ± - FINISH SEE TABLE		PRODUCT SPEC 108-14008	SIZE A2	RESTRICTED TO -
MATERIAL 1		APPLICATION SPEC 114-26004	CAGE CODE 00779	REV 0
		WEIGHT -	SCALE 1:1	SHEET 1 of 1
		CUSTOMER DRAWING		

5645994