

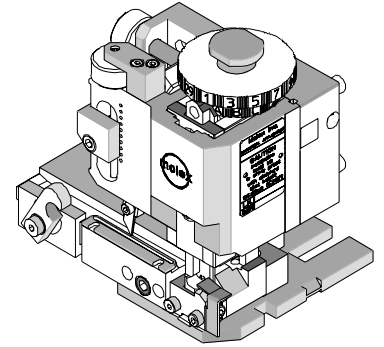

# FineAdjust Applicator Specification Sheet 18-22 AWG CRC Terminals Part No. 63865-9000



## FEATURES

- Quick punch removal with the push of a button for fast and easy tooling change
- Applicator designed to industry standard mounting and shut height 135.80mm (5.346")
- Quick set-up time; plus the crimp height, track and feed adjustments can be set without removing the applicator from the press
- Fine adjustment allows users to achieve target with little effort by adjusting in increments of 0.15mm (.0006") for conductor crimp height and .063mm (.0025") for insulation height
- Independent adjustment rings allow users to quickly adjust the conductor or insulation crimp height without affecting each other
- Directly adapts to most automatic wire processing machines

## SCOPE

Terminal Series No.	Terminal Order No.			Wire Size		Insulation Diameter		Strip Length	
				AWG	mm <sup>2</sup>	mm	In.	mm	In.
56117	56117-8090	56117-8228	56117-8299	18 - 22	0.80-0.35	2.20 Max	.087 Max	2.70-3.20	.106-.126
	56117-8099	56117-8290							
56119	56119-8090	56119-8228	56119-8299	18 - 22	0.80-0.35	2.20 Max	.087 Max	2.70-3.20	.106-.126
	56119-8099	56119-8290							
56121	56121-8090	56121-8299	56121-8628	18 - 22	0.80-0.35	2.20 Max	.087 Max	2.70-3.20	.106-.126
	56121-8099	56121-8428	56121-8690						
	56121-8228	56121-8490	56121-8699						
	56121-8290	56121-8499							

## DEFINITION OF TERMS

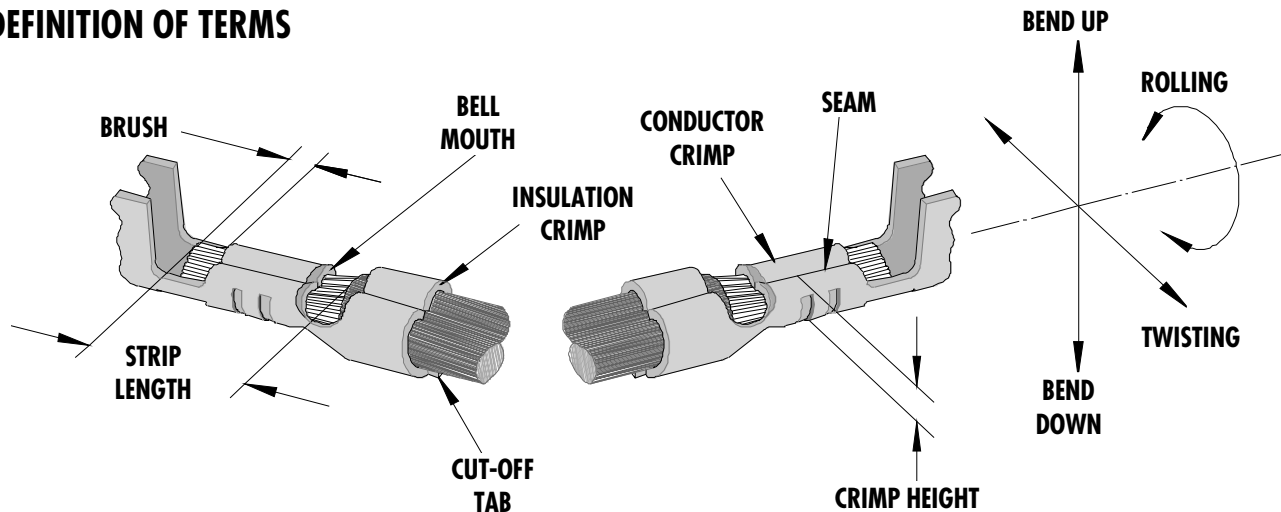

The above terminal drawing is a generic terminal representation. It is not an image of a terminal listed in the scope.

**CRIMP SPECIFICATION**

Terminal Series No.	Bell mouth		Cut-off Tab Max.		Conductor Brush	
	mm	In.	mm	In.	mm	In.
56117-8***	0.10-0.60	.004-.024	0.25	.010	0.00-0.50	.000-.020
56119-8***	0.10-0.60	.004-.024	0.25	.010	0.00-0.50	.000-.020
56121-8***	0.10-0.60	.004-.024	0.25	.010	0.00-0.50	.000-.020

Terminal Series No.	Bend up Bend down		Twist Roll		Punch Width mm (Ref)				Seam Seam shall not be open and no wire allowed out of the crimping area
	Degree		Degree		Conductor		Insulation		
					mm	In	mm	In	
56117-8***	4	3	4	8	1.50	.059	2.20	.086	
56119-8***	4	3	4	8	1.50	.059	2.20	.086	
56121-8***	4	3	4	8	1.50	.059	2.20	.086	

After crimping, the conductor profile should measure the following.

Terminal Series No.	Wire Size		Crimp Height		Pull Force Min.	
	AWG	mm <sup>2</sup>	mm	In.	N	Lb.
56117-8***	18	0.80	1.12-1.22	.044-.048	88.2	19.80
56117-8***	20	0.50	0.96-1.06	.038-.042	58.8	13.20
56117-8***	22	0.35	0.89-0.94	.035-.037	39.2	8.80
56119-8***	18	0.80	1.12-1.22	.044-.048	88.2	19.80
56119-8***	20	0.50	0.96-1.06	.038-.042	58.8	13.20
56119-8***	22	0.35	0.89-0.94	.035-.037	39.2	8.80
56121-8***	18	0.80	1.12-1.22	.044-.048	88.2	19.80
56121-8***	20	0.50	0.96-1.06	.038-.042	58.8	13.20
56121-8***	22	0.35	0.89-0.94	.035-.037	39.2	8.80

Pull Force should be measured with no influence from the insulation crimp.

The above specifications are guidelines to an optimum crimp.

**PARTS LIST**

Item	Order No	Engineering No.	Description	Quantity
	<b>63865-9000</b>	<b>63865-9000</b>	<b>FineAdjust Applicator (Fig. 1)</b>	<b>REF</b>
1	63444-1515	63444-1515	Conductor Punch	1 Y
2	63445-1521	63445-1521	Conductor Anvil	1 Y
3	63446-2239	63446-2239	Insulation Punch	1 Y
4	63445-2261	63445-2261	Insulation Anvil	1 Y
5	63443-0003	63443-0003	Cut-Off Plunger	1 Y
6	63443-0012	63443-0012	Front Plunger Retainer	1 Y
7	11-18-4083	60707-8	Front Cover	1
8	11-24-1067	4996-4	Cut-off Plunger Spring	1
9	63443-0009	63443-0009	Scrape Chute	1
10	63443-0021	63443-0021	Lower Tooling Key	1
11	63443-2422	63443-2422	Anvil Mount	1
12	63443-3101	63443-3101	Front Plunger Striker	1
13	63443-4025	63443-4025	Wire Stop	1
14	63443-6003	63443-6003	Rear Cover	1
15	63800-4900	63800-4900	Fine Adjust Applicator Frame	1
16	N/A	N/A	M3 by 6Lg. SHCS	2**
17	N/A	N/A	M4 by 6Lg. SHCS	1**
18	N/A	N/A	M4 by 12Lg. BHCS	2**
19	N/A	N/A	M4 by 16Lg SHCS	1**
20	N/A	N/A	M4 by 20Lg. SHCS	1**
21	N/A	N/A	M4 by 50Lg. SHCS	1**
22	N/A	N/A	3MM by 6Lg. Roll Pin	1**
23	N/A	N/A	#10-32 by 1/4"Lg. BHCS	1**
	<b>63865-9070</b>	<b>63865-9070</b>	<b>Tool Kit (All Y Items)</b>	<b>REF</b>

\*\* The following purchased parts are available from an Industrial supply company such as MSC (1-800-645-7270).



## NOTES

1. Molex recommends an extra perishable tooling kit be maintained at your facility.
2. Verify tooling alignment by manually cycling the press and Applicator before crimping under power. Check that all screws are tight.
3. Slugs, Terminals, Dirt and Oil should be kept clear of work area.
4. Wear safety glasses at all times.
5. For recommended maintenance refer to the FineAdjust Manual.

**CAUTION:** This applicator should only be used in a press with a shut height of 135.8 mm (5.346"). Tooling damage could result at a lower setting.

**CAUTION:** To prevent injury never operate this Applicator without the guards supplied with the press or wire-processing machine in place. Reference the press or wire processing manufacturer's instruction manual.

**CAUTION:** Molex crimp specifications are valid only when used with Molex terminals, applicators and tooling.

### Molex Application Tooling Group

1150 E. Diehl Road  
Naperville, IL 60563  
Tel: (630) 969-4550  
Fax: (630) 505-0049

Visit our Web site at <http://www.molex.com>