

8/29/89 16:23 * 99241 15:52 * RELEASE * 10-820100/119 0001

4

3

2

1

REVISIONS				
ZONE	LTR	DESCRIPTION	DATE	APPROVED
	C	(CLII) ADDED NOTE 8 ECN: 22391	08/29/89 BURNSIDE	m.n. J.B.
	D	(CLII) CHANGE BLOCK CHANGE ONLY WAS SHELL 10-617702-XX3 (NO SLOT) ECN: 90048	11-18-04 DEMATTEO	ged

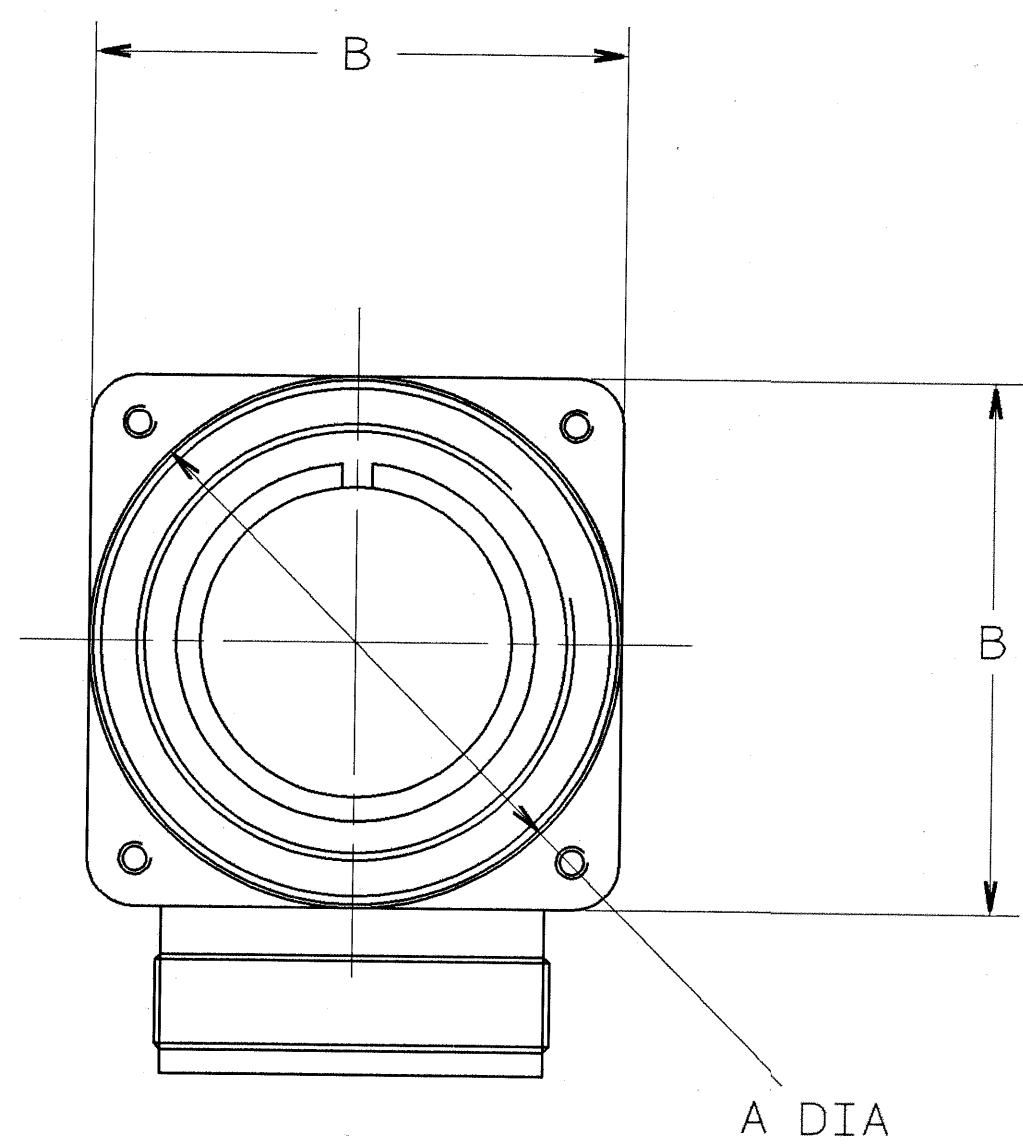
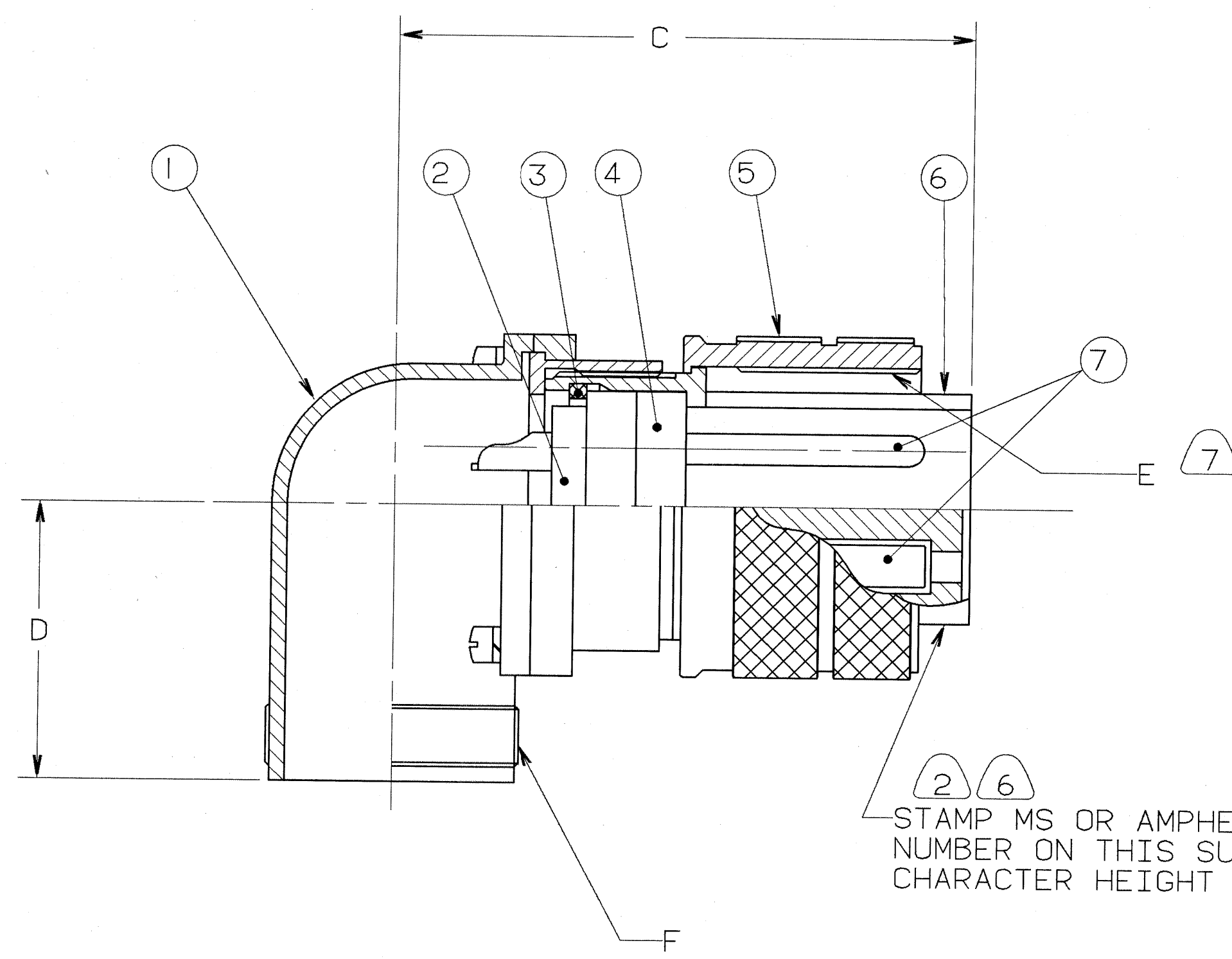

STAMP MS OR AMPHENOL ASSEMBLY NUMBER ON THIS SURFACE. CHARACTER HEIGHT .062 MINIMUM.

FIND NO.	QTY REQD.	FSCM NO.	PART NUMBER	DESCRIPTION	NOTE REF.
7	SEE NOTE		SEE NOTE 1	CONTACTS	
6				SHELL	
5				RING, COUPLING	7
4				INSERT, FRONT	
3				RING, RETAINING	
2				INSERT, REAR	
1				HOUSING ASSEMBLY	

UNLESS OTHERWISE SPECIFIED LINEAR DIMENSIONS ARE IN INCHES.
TOLERANCES: .XXX±.010,
.XX ±.03, .X ±.1,
ANGLES ±2°.
OTHER STANDARDS PER 9-3800 AND DOD-D-1000.
NOTE REF. =

SPECIFICATIONS		SIGNATURES		DATES		PARTS LIST			
MATERIAL SPEC.	N/A	PREPARED	A. PRESCOTT	11/03/87	AMPHENOL CORPORATION BENDIX CONNECTOR OPERATIONS SIDNEY, N.Y.				
PROCESS SPEC.	9-2437-33	CHECKED	PHILPOTT	11/12/87	CONNECTOR, ELECTRICAL PLUG, TYPE 97-3108A, OLIVE DRAB CADMIUM PLATE.				
		APPROVED	BERNHARDT	11/13/87	SIZE	FSCM NO.	10-820100/119	REV.	D
		APPROVED	HAYNER	11/17/87	C	77820			
		1ST PART NO.	10-820102-03S		SCALE	NONE	WT.	REF	N/A
					SHEET	1 OF 2		TAB.	

SEE SHEET 2.
NOTES:

THE USE OF THIS DOCUMENT IS UNLIMITED. HOWEVER, DOCUMENTS REFERENCED HEREON MAY CONTAIN LIMITED RIGHTS DATA.

N/A
N/A
NEXT ASSEMBLY

COMPUTER GENERATED DRAWING.

000000001 01250

IMAGED / Nov 22 2004 02:49 PM

97-3108A

B

A

D

C

B

A

D

C

B

A

8/29/99 16:23 * 89241 15:23 * PRELISE * 10-820100/119 0002

D

C

B

A

D

C

B

A

4		3				2		1
BENDIX ASSEMBLY NUMBER	AMPHENOL ASSEMBLY NUMBER	MS ASSEMBLY NUMBER	A DIA.	B	C	D	E THREAD	F THREAD
10-820100-()	97-3108A- 8S -()	MS3108A- 8S -()	.750	.781	1.250	.875	.5000-28 UNEF-2B	.5000-28 UNEF-2A
1-()	-10S -()	-10S -()	.875	.781	1.250	.875	.6250-24 UNEF-2B	.5000-28 UNEF-2A
2-()	-10SL-()	-10SL-()	.875	1.063	1.312	1.000	.6250-24 UNEF-2B	.6250-24 UNEF-2A
3-()	-12S -()	-12S -()	1.000	1.063	1.375	1.000	.7500-20 UNEF-2B	.6250-24 UNEF-2A
4-()	-12SL-()	-12SL-()	1.000	1.063	1.375	1.000	.7500-20 UNEF-2B	.7500-20 UNEF-2A
5-()	-12 -()	-12 -()	1.000	1.063	1.203	1.000	.7500-20 UNEF-2B	.6250-24 UNEF-2A
6-()	-14S -()	-14S -()	1.125	1.063	1.375	1.000	.8750-20 UNEF-2B	.7500-20 UNEF-2A
7-()	-14 -()	-14 -()	1.125	1.063	1.812	1.000	.8750-20 UNEF-2B	.7500-20 UNEF-2A
8-()	-16S -()	-16S -()	1.250	1.312	1.500	1.125	.8750-20 UNEF-2B	.7500-20 UNEF-2A
9-()	-16 -()	-16 -()	1.250	1.312	1.938	1.125	1.0000-20 UNEF-2B	.8750-20 UNEF-2A
10-820110-()	-18 -()	-18 -()	1.344	1.312	1.938	1.125	1.1250-18 UNEF-2B	1.0000-20 UNEF-2A
1-()	-20 -()	-20 -()	1.469	1.625	2.063	1.312	1.2500-18 UNEF-2B	1.1875-18 UNEF-2A
2-()	-22 -()	-22 -()	1.594	1.625	2.063	1.312	1.3750-18 UNEF-2B	1.1875-18 UNEF-2A
3-()	-24 -()	-24 -()	1.719	2.000	2.469	1.500	1.5000-18 UNEF-2B	1.4375-18 UNEF-2A
4-()	-28 -()	-28 -()	1.969	2.000	2.469	1.500	1.7500-18 UNEF-2B	1.4375-18 UNEF-2A
5-()	-32 -()	-32 -()	NOT AVAILABLE					
6-()	-36 -()	-36 -()	NOT AVAILABLE					
7-()	-40 -()	-40 -()	NOT AVAILABLE					
8-()	-44 -()	-44 -()	NOT AVAILABLE					
9-()	-48 -()	-48 -()	NOT AVAILABLE					

TO COMPLETE, ADD APPLICABLE INSERT ARRANGEMENT SUFFIX PER 9-2437-33. 6

8. IDENTIFY PACKAGE WITH APPLICABLE MS OR 97- PART NUMBER PER NOTE 6.
7. APPLY LUBRICANT 9-7568 TO THREADS OF COUPLING RING.
6. FOR BENDIX INSERT ARRANGEMENT SUFFIX -1 THROUGH -49, STAMP MS ASSEMBLY NUMBER. FOR BENDIX INSERT ARRANGEMENT SUFFIX -50 THROUGH -99, AND -AA THROUGH -BC, STAMP AMPHENOL ASSEMBLY NUMBER.
5. FOR CONTACT ARRANGEMENT, SEE MIL-STD-1651 AND L-22208-() THROUGH L-22248-().
4. PACKAGE PER PRODUCTION PROCESS SHEET.
3. UNITS MEET THE APPLICABLE REQUIREMENTS OF MIL-C-5015.
2. SEE WORK ORDER FOR PERMISSIBLE ADDITIONAL OR ALTERNATE STAMPING.
1. SEE SEPARATE PARTS LIST FOR COMPONENT PART NUMBERS AND QUANTITIES.

NOTES:

THE USE OF THIS DOCUMENT IS UNLIMITED. HOWEVER, DOCUMENTS REFERENCED HEREON MAY CONTAIN LIMITED RIGHTS DATA.

COMPUTER GENERATED DRAWING

IMAGED / Nov 22 2004 02:49 PM

SIZE	FSCM NO.	REV.
C	77820	D
SCALE	WT.	REF.
SHEET		2

97-3108A

TAB.