

CONSTRUCTION INSIDE
(FOR REFERENCE)

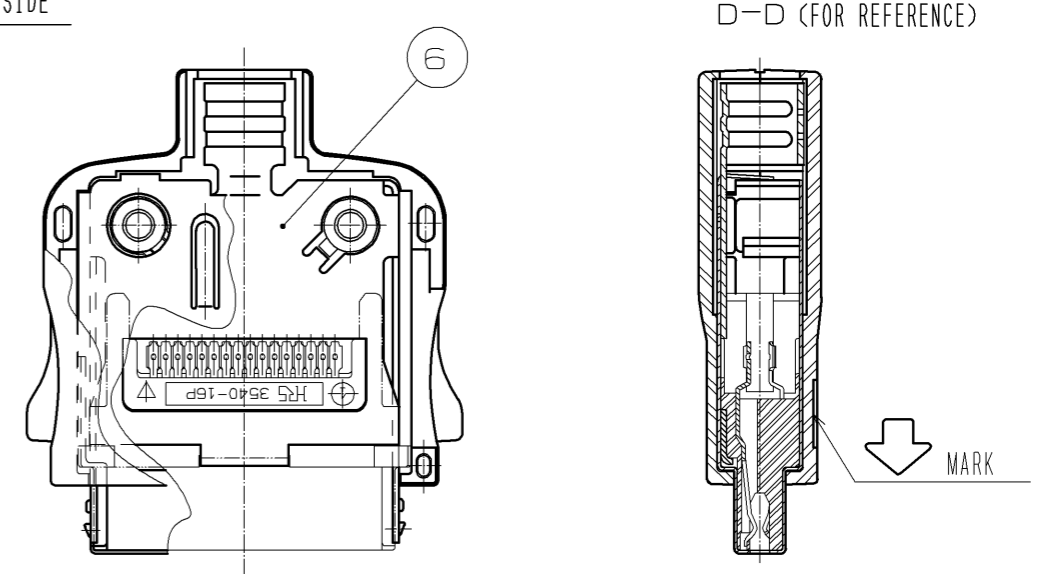

CONNECTOR UNIT

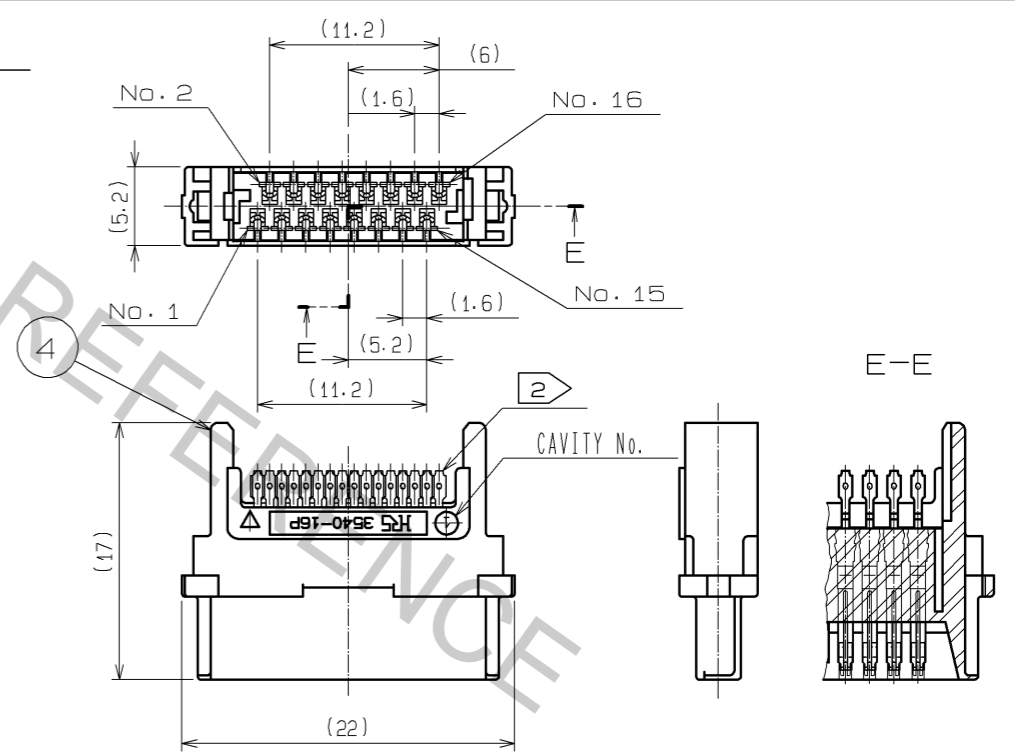

NOTES 1. THIS PRODUCT SHALL BE IN DISASSEMBLED CONDITION (EXCEPT CONNECTOR UNIT ③, ④) WHEN DELIVERED.
2. EACH TERMINATING POINT SHALL BE COVERED WITH HEAT SHRINK TUBE AFTER SOLDERING ASSEMBLY.

3	COPPER ALLOY	CONTACT: GOLD PLATING 0.2 μm MIN PALLADIUM PLATING 0.7 μm MIN	7	STEEL	BLACK	TAPPING SCREW
2	POLYCARBONATE	BLACK UL94V-0 Δ	6	STAINLESS STEEL		
1	POLYCARBONATE	BLACK UL94V-0 Δ	5	STAINLESS STEEL		
		LEAD : GOLD PLATING 0.03 μm MIN UNDER : NICKEL PLATING 1.27 μm MIN	4	POLYAMIDE	BLACK	UL94V-0
NO.	MATERIAL	FINISH, REMARKS	NO.	MATERIAL	FINISH, REMARKS	
UNITS mm		SCALE 2 : 1	COUNT 2	DESCRIPTION OF REVISIONS DIS-E-004505		DESIGNED TA. ASO
		APPROVED : YH. ENAMI 08.09.29	DRAWING NO. EDC3-120517-03		CHECKED NM. NISHIMATSU	
HIROSE ELECTRIC CO., LTD.		CHECKED : KI. NAGANUMA 08.09.29	PART NO. 3540-16P-CV(51)		DATE 13.02.05	
		DESIGNED : MT. ITANO 08.09.29	CODE NO. CL235-0004-1-51			
		DRAWN : MT. ITANO 08.09.29				