

OPTIONAL TERMINALS FOR PUSH ON OR SOLDER CONNECTIONS (.032 X .250) [0.8 X 6.4]

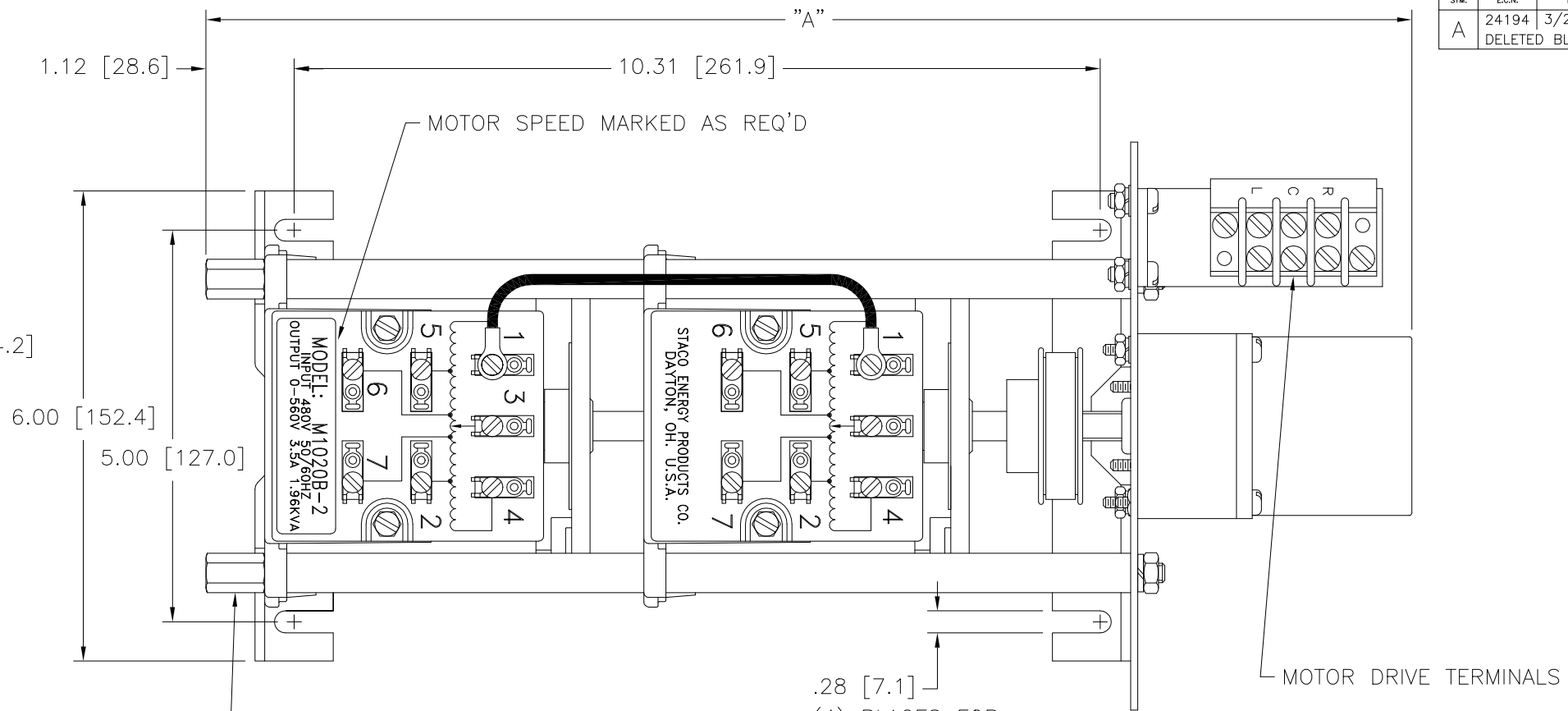

(4) STANDOFFS TAPPED 1/4-28 X .38 [9.5] DEEP FOR MOUNTING BOLTS

(4) PLACES FOR CUSTOMER MOUNTING

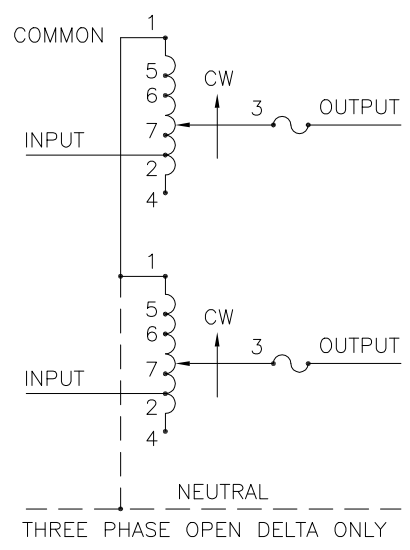

SCHEMATIC THREE PHASE OPEN DELTA AND SINGLE PHASE SERIES. FUSE RECOMMENDED BUT NOT SUPPLIED.

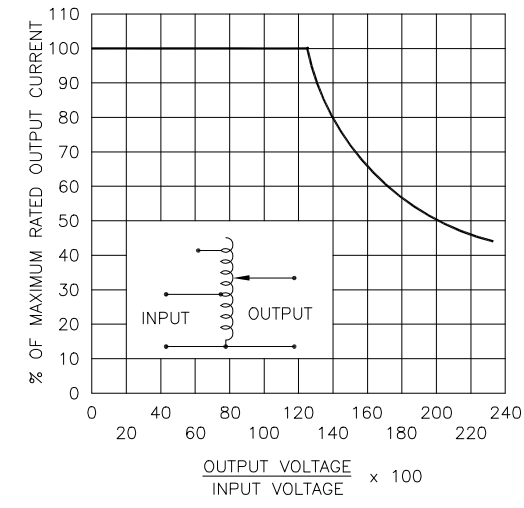
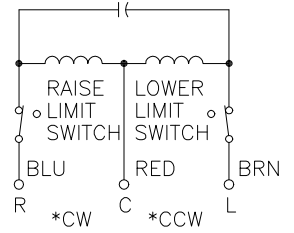

FIGURE A  
 MAXIMUM OUTPUT CURRENT OF ANY DUAL INPUT VOLTAGE OR VOLTAGE DOUBLER UNIT OPERATED AT LOWER INPUT VOLTAGE.



MOTOR CIRCUIT  
 120V, 50/60 HZ  
 \* ROTATION AS VIEWED FROM MOTOR END  
 MOTOR SPEED: SEE CHART

- # MAXIMUM OUTPUT CURRENT IN OUTPUT VOLTAGE RANGE FROM 0 TO 25% ABOVE LINE VOLTAGE. AT HIGHER OUTPUT VOLTAGES, THE OUTPUT CURRENT MUST BE REDUCED ACCORDING TO THE DERATING CURVE FIGURE A.
- S MAXIMUM KVA AT MAXIMUM OUTPUT VOLTAGE AND CORRESPONDING DERATED OUTPUT CURRENT. MAXIMUM KVA FOR LOWER VOLTAGES MAY BE CALCULATED FROM DERATING CURVE FIGURE A.
- ∏ IF GANGED UNITS ARE USED IN A SYSTEM THAT ORDINARILY HAS A COMMON NEUTRAL OR GROUND BETWEEN SOURCE AND LOAD, THE NEUTRAL OR GROUND MUST BE CONNECTED TO THE COMMON TERMINALS OF THE VARIABLE TRANSFORMER ASSEMBLY. IF THE SYSTEM HAS NO NEUTRAL, THE LOAD MUST BE BALANCED OR THE TRANSFORMER WILL BE DAMAGED.
- JUMPER PROVIDED IN STANDARD COMMON POSITION AND SHOULD BE MOVED OR REMOVED AS REQUIRED.
- ++ LINE TO LINE VOLTAGE.
- + MOTOR DRIVEN UNITS USE TERMINAL CONNECTIONS FOR CCW INCREASING VOLTAGE AS VIEWED FROM BASE END.

SPEED (SECONDS)	MODEL NUMBER	DIM "A"
5	5M1020B-2	15.40 [391.2]
15	15M1020B-2	15.40 [391.2]
30	30M1020B-2	15.79 [401.1]
60	60M1020B-2	15.79 [401.1]

SPECIFICATIONS											
WIRING	INPUT		OUTPUT				SHAFT ROTATION TO INCREASE VOLTAGE	TERMINAL CONNECTIONS			
	VOLTS	HERTZ	VOLTS	CONSTANT CURRENT LOAD MAX. AMPS	CONSTANT IMPEDANCE LOAD MAX. KVA	MAX. AMPS		MAX. KVA	FOR INCREASING VOLTAGE AS VIEWED FROM BASE END +		
SINGLE PHASE SERIES	480	50/60	0-480	3.5	1.68	5.0	2.4	CW	1-1	4-4	3-3
			0-560	3.5	1.96	—	—	CCW	4-4	1-1	3-3
	240	50/60	0-560	3.5#	0.84 <sup>S</sup>	—	—	CW	5-5	4-4	3-3
			0-280	3.5	1.70	—	—	CCW	2-2	1-1	3-3
THREE PHASE OPEN DELTA ∏	240	50/60	0-240	3.5	1.45	5.0	2.08	CW	1-4-1	4-4	3-4-3
			0-280	3.5	1.70	—	—	CCW	4-1-4	1-1	3-1-3
	120	50/60	0-280	3.5#	0.73 <sup>S</sup>	—	—	CW	5-4-5	4-4	3-4-3
			0-280	3.5	1.70	—	—	CCW	2-1-2	1-1	3-1-3
			0-280	3.5	1.70	—	—	CW	7-4-7	4-4	3-4-3
			0-280	3.5	1.70	—	—	CCW	6-1-6	1-1	3-1-3

UNLESS OTHERWISE SPECIFIED, TOLERANCE IS # DECIMALS .XX .XXX .005 HOLES .002 ANGLES 1° DRAFT 1-1/2° UNITS IN [mm] MATERIAL: ALL DIMENSIONS APPLY AFTER PLATING

TITLE: SPEC. CONTROL DRAWING MOTORIZED VARIABLE XFMR MODEL: M1020B-2

STACO ENERGY PRODUCTS CO. A COMPONENTS CORPORATION OF AMERICA COMPANY DAYTON, OHIO U.S.A.

DRAWN BY S.A. SMITH DATE 9/24/97 FIRST USED ON DATE DO NOT SCALE DWG. CUSTOMER APPROVAL DATE

CHECKER DATE WEIGHT APPROX. 28.25 LBS CODE IDENT. NO. 83008 DWG. NO. 031-2440

ENGINEER DATE SCALE 1=1 SHEET 1 OF 1