

JUPITER™ SOLUTIONS

Datasheet (Preliminary)

JS-3M



Extra Low Power Smart GPS Sensor

July 17, 2011

Related Documents

- Navman Wireless OEM NMEA reference manual
- SiRF Binary Protocol reference manual

CONTENTS

1.0	Introduction	1	Figures	
2.0	Technical description	1	Figure 2-1:	Receiver architecture2
2.1	Product applications	1	Figure 2-2:	JS-3M – Physical dimension3
2.2	Receiver architecture.....	2	Figure 3-1:	LED indicator duty cycl6
2.3	Physical characteristics	2	Figure 4-1:	RJ11 connector and electrical connection8
2.4	Mechanical specifications – Physical dimensions and pin out assignments	3		
2.4.1	JS-3M – Physical dimensions	3	Tables	
2.5	Environmental	4	Table 3-1: Acquisition times at –125 dBm	5
3.0	Performance characteristics.....	5	Table 3-2: Sensitivity.....	7
3.1	TTFF (Time To First Fix)	5	Table 3-3: Position and velocity accuracy.....	7
3.1.1	Hot start.....	5	Table 4-1: Power consumption (continuous mode)	8
3.1.2	Warm start.....	5	Table 5-1: Default NMEA messages	9
3.1.3	Cold start.....	5	Table 5-2: Proprietary message parameters	9
3.2	Acquisition times	5	Table 5-3: Proprietary NMEA input messages.....	10
3.3	Two LED indicators.....	6	Table 7-1: Ordering information	10
3.4	Power management.....	6		
3.4.1	Adaptive TricklePower.....	6		
3.5	Differential aiding	6		
3.5.1	Satellite Based Augmentation Systems (SBAS).....	6		
3.6	Sensitivity	7		
3.7	Dynamic constraints.....	7		
3.8	Position and velocity accuracy	7		
3.9	Multi-mode aiding.....	7		
4.0	Electrical requirements	8		
4.1	Power consumption	8		
4.2	Electrical connections	8		
4.3	Back-up battery	8		
5.0	Software interface	9		
5.1	NMEA output messages.....	9		
5.1.1	Proprietary NMEA messages	9		
5.1.2	Proprietary NMEA input messages.....	10		
6.0	Product handling	10		
6.1	Packaging and delivery	10		
6.2	Safety.....	10		
6.3	Disposal	10		
7.0	Ordering information.....	10		
8.0	Glossary and acronyms	11		

1.0 Introduction

JS-3M from Jupiter Solutions is a complete GPS receiver that has included the magnetic mount plastic housing and high performance J-3A GPS receiver board. This datasheet specifies the performance of the 20-channel ultra-high sensitivity J-3A receiver board which is based on the proven Jupiter3 GPS module. JS-3M provides the fastest TTFF (Time to First Fix) possible for all weather conditions, in challenging environments such as densely built cities, heavy foliage, and enclosed spaces. Jupiter Solutions is offered in volume purchase as indicated in Section 7 Ordering Information.

2.0 Technical description

JS-3M has enhanced the architecture of the Jupiter3 module by adding carefully selected key components including antenna, LNA, LDO, back-up battery and driver to comprise the complete receiver solution. This ensures frequency stability, optimized sensitivity at chipset level down to -159 dBm, lower power consumption and a faster TTFF (Time To First Fix).

By providing the on-board micro-battery, the JS-3M allows rapid satellite acquisition times by preserving system data in SRAM and the power to the RTC section of the Jupiter3 module.

Protocols supported are selected NMEA (National Marine Electronics Association) data messages and SiRF Binary.

2.1 Product applications

The JS-3M offers high performance and maximum flexibility in a wide range of OEM configurations. The four pins digital interface makes it ideal for:

- navigation systems – where athermic glass, or an unsuitably positioned antenna inside the vehicle will reduce visibility and signal strength
- vehicle and people tracking devices – where satellites are obstructed by partially covered car parks and walkways, tracking even continues indoors
- marine buoys – where multipath and unstable sea conditions make satellite visibility irregular
- asset tracking – where construction machinery is located in covered yards and areas of dense foliage
- people tracking - home detention and house arrest applications, emergency location services

2.2 JS-3M functional architecture

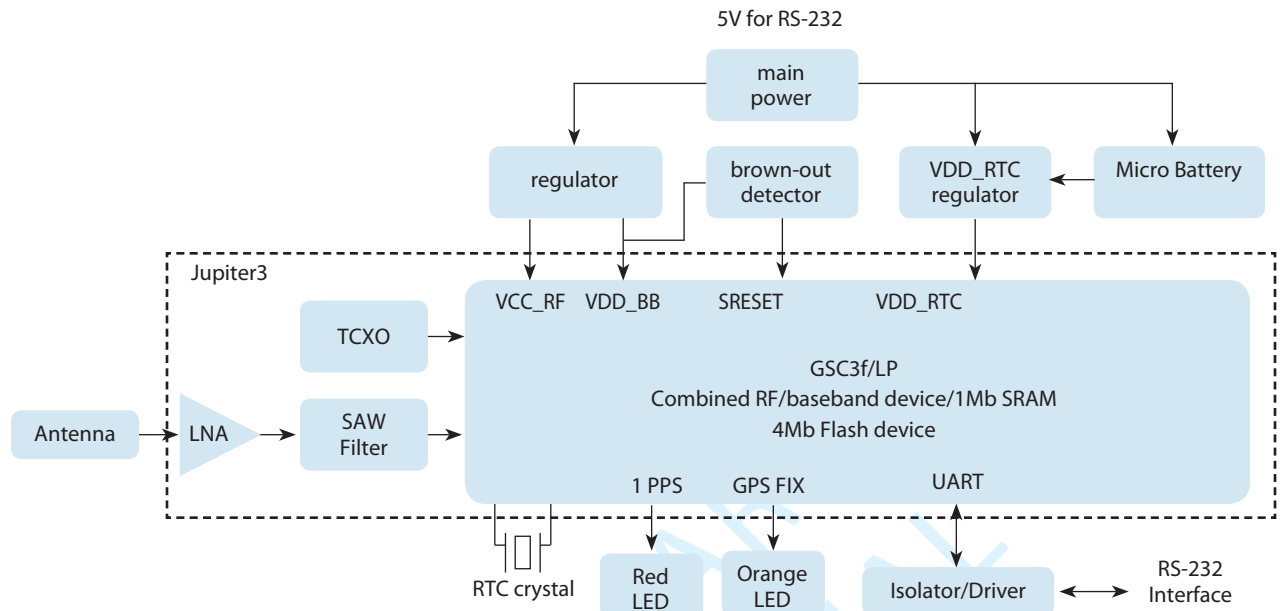

Figure 2-1: JS-3M GPS Receiver Architecture

2.3 Physical characteristics

The JS-3M is a complete GPS sensor within an enclosed housing that is waterproof to IPx7. The standard cable is 3m in length with a RJ11 connector. If customization on cable length and connector are required, please contact our sales manager for details.

2.4 Mechanical specification

2.4.1 JS-3M: Physical dimensions

Dimensions in mm:

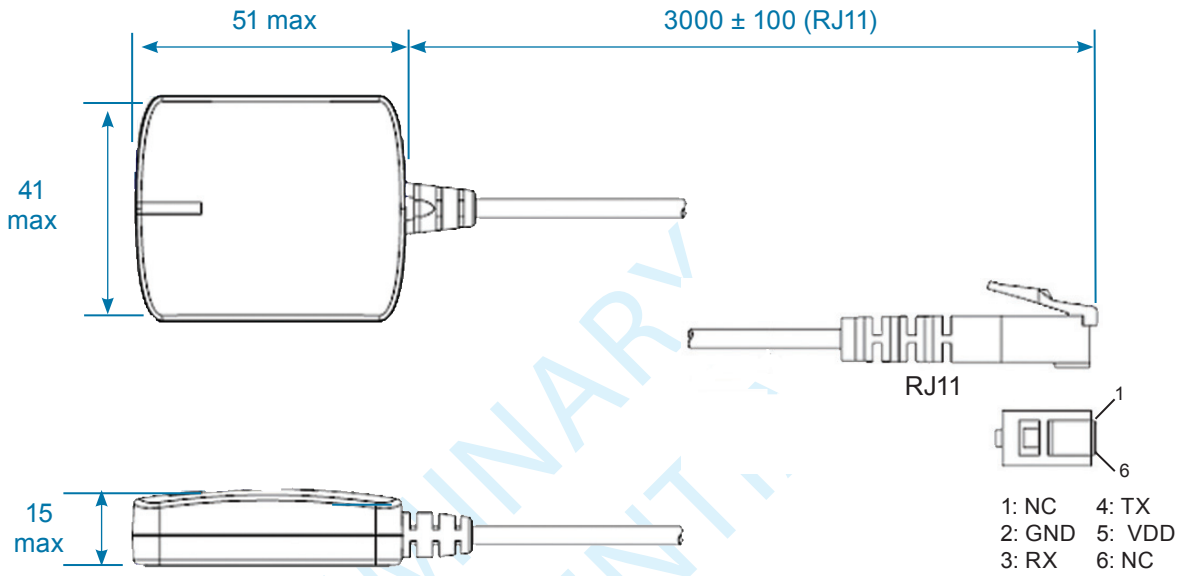

Figure 2-2: JS-3M: Physical dimensions

2.5 Environmental

Environmental operating conditions:

operating temperature (T_{opr}): -20°C to +60°C

storage temperature (T_{stg}): -40°C to +60°C (25°C typical)

humidity: up to 95% non-condensing or a wet bulb temperature of +35°C

altitude: -304 m to 18 000 m

vibration: random vibration IEC 68-2-64

max. vehicle dynamics: 500 m/s

shock (non-operating): 50 G peak, 11 ms

PRELIMINARY
CONFIDENTIAL

3.0 Performance characteristics

3.1 TTFF (Time To First Fix)

TTFF is the actual time required by a GPS receiver to achieve a position solution. This specification will vary with the operating state of the receiver, the length of time since the last position fix, the location of the last fix, and the specific receiver design.

Aiding is a method of effectively reducing the TTFF by making every start Hot or Warm.

3.1.1 Hot start

A hot start results from a software reset after a period of continuous navigation, or a return from a short idle period (i.e. a few minutes) that was preceded by a period of continuous navigation. In this state, all of the critical data (position, velocity, time, and satellite ephemeris) is valid to the specified accuracy and available in SRAM. Battery backup of the SRAM and RTC during loss of power is required to achieve a hot start.

3.1.2 Warm start

A warm start typically results from user-supplied position and time initialization data or continuous RTC operation with an accurate last known position available in memory. In this state, position and time data are present and valid but ephemeris data validity has expired.

3.1.3 Cold start

A cold start acquisition results when either position or time data is unknown. Almanac information is used to identify previously healthy satellites.

3.2 Acquisition times

Table 3-1 shows the corresponding TTFF times for each of the acquisition modes.

Mode	@ -125 dBm	
	Typ	90%
hot start TTFF	500 ms	< 1 s
warm start TTFF	31 s	36 s
cold start TTFF	33 s	38 s
re-acquisition (<10 s obstruction)	< 1 s	

Table 3-1: Acquisition times at -125 dBm

3.3 Two LED indicators

JS-3M has two on-board LEDs on the antenna side for status indication. The Red LED will blink once every second after the position is fixed. The Orange LED will stay off after position fix.

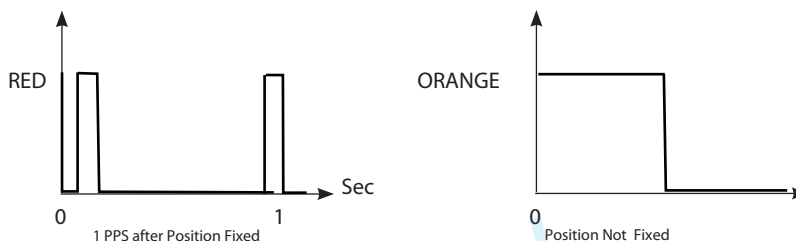

Figure 3-1: LED indicator duty cycle for RS-232 Version

3.4 Power management

JS-3M offers Adaptive TricklePower, which can be set using NMEA or SiRF Binary messages.

3.4.1 Adaptive TricklePower

JS-3M can use the Adaptive TricklePower (ATP) feature, which reduces power consumption by intelligently switching between full power in tough GPS environments and low power in strong GPS signal areas.

When signal levels drop, the receiver returns to full power so that message output rates remain constant. This results in variable power savings but much more reliable performance for a fixed output rate. Applications using ATP should give performance very similar to full power, but with significant power savings in strong signal conditions.

ATP is best suited for applications that require solutions at a fixed rate as well as low power consumption and still maintain the ability to track weak signals.

With ATP at a 1 second update, a power saving of 50% can easily be achieved with minimal degradation in navigation performance.

For further information refer to:

- Navman Wireless Low Power Operating Modes application note (LA000513)
- Navman Wireless OEM NMEA reference manual
- SiRF Binary Protocol reference manual

3.5 Differential aiding

3.5.1 Satellite Based Augmentation Systems (SBAS)

JS-3M is capable of receiving SBAS differential corrections including WAAS and EGNOS. SBAS improves horizontal position accuracy by correcting GPS signal errors caused by ionospheric disturbances, timing and satellite orbit errors.

3.6 Sensitivity

Sensitivity of the JS-3M at chipset level is measured assuming a system noise value of 3 dB. The sensitivity values are as follows:

Parameter	Signal strength	C/N ₀
acquisition – cold start	-145 dBm	25dBHz
acquisition – hot start	-155 dBm	15 dBHz
navigation	-158dBm	12dBHz
tracking	-159 dBm	10 dBHz

Table 3-2: Sensitivity

3.7 Dynamic constraints

The JS-3M is programmed to deliberately lose track if any of the following limits is exceeded:

- velocity 2D (2 sigma): 500 m/s max
- acceleration: 4 G (39.2 m/s²) max
- vehicle jerk: 5 m/s³ max
- altitude: 18000 m max (referenced to MSL)

3.8 Position and velocity accuracy

Position and velocity accuracy are shown in Table 3-3, assuming full accuracy C/A code. These values are the same in normal operation and when Adaptive TricklePower is active.

Parameter	Value
horizontal CEP*	2.5m
horizontal (2 dRMS)	5.5m
vertical VEP*	2.0m
velocity (speed)**	< 0.1 m/s
velocity (heading)**	< 0.1
*position error 50% and under normal open sky conditions	
**In 3D Kalman filtered mode in steady state open sky conditions	

Table 3-3: Position and velocity accuracy

3.9 Multi-mode aiding

Multi-mode aiding technology makes navigation information available to GPS devices when Satellite Vehicles (SVs) are not visible due to obstruction. In autonomous operation mode, the GPS receiver requires a signal level of 28 dBHz or higher in four or more SVs to download ephemerides. This requires an uninterrupted full 30 seconds of data reception from each SV. If data is not received in full, the ephemeris data collection starts again at the next cycle.

Ephemeris Push is the multi-mode aiding currently supported by the JS-3M (Binary mode only). This feature supports live ephemeris data download from application servers, which is then transmitted to the GPS receiver through a network connection. This feature facilitates hot start performance at all times, including weak conditions and moving start ups. The ephemeris is typically valid for 4 hours until the live ephemeris is downloaded or new ephemeris data is provided.

An application note about Ephemeris Push is in preparation and will be available at a later date.

4.0 Electrical requirements

4.1 Power consumption

See Table 4-1 for JS-3M continuous mode power consumption details.

Parameter	Symbol	Product	Min	Typ	Max
input voltage	VCC	JS-3M	3.3V	5V	6V
input current	Icc	JS-3M	33mA*	40mA*	55mA*
*measured when position fix is available					

Table 4-1: Power consumption (continuous mode)

4.2 Electrical Connections

The JS-3M has a six pins RJ11 connector as shown in Figure 4-1 below. The table contains electrical properties for each of these connections.

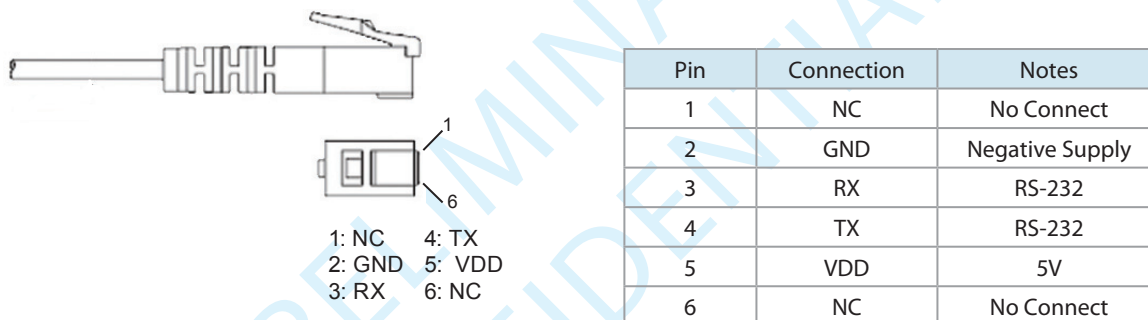

Figure 4-1: RJ11 connector and electrical connections

4.3 Back-up Battery

The JS-3M has a 5.5mAh lithium rechargeable battery (Seiko MS621FE) to allow rapid satellite acquisition times by preserving system data in SRAM and the power to the RTC section of the Jupiter3 module. Battery charging occurs anytime the VCC supply is present. This battery is rated for 100 cycle life where the battery is 100% discharged; however as long as the power is applied for a few hours every three to four days, a full discharge will not occur.

5.0 Software interface

Protocols supported are selected NMEA (National Marine Electronics Association) -0183 and SiRF Binary messages: latitude, longitude, elevation, velocity, heading, time, satellite tracking status, command/control messages.

The default serial modes are as follows:

NMEA, 9600 bps, 8 data bits, no parity, 1 stop bit

5.1 NMEA output messages

NMEA is a standard protocol used by GPS receivers to transmit data. The output NMEA (0183 v3.0) messages for the JS-3M are listed in Table 5-1. A complete description of each NMEA message is contained in the Navman Wireless OEM NMEA reference manual.

Message ID and description	Refresh rate
GGA – global positioning system fix data	1 s
GLL – geographic position - latitude, longitude	1 s
GSV – satellites in view	1 s
GSA – DOP and active satellites	1 s
RMC – recommended minimum specific GPS data	1 s
VTG – course over ground and ground speed	1 s
ZDA – PPS timing message	1 s

Table 5-1: Default NMEA messages

5.2 Proprietary NMEA messages

Table 5-2 shows the proprietary message parameters.

Start sequence	Payload	Checksum	End sequence
\$PSRF<MID> ¹	Data ²	CKSUM ³	<CR><LF> ⁴
<ol style="list-style-type: none"> 1. Message Identifier consisting of three numeric characters. Input messages begin at MID 100. 2. Message specific data. Refer to a specific message section for <data>...<data> definition. 3. CKSUM is a two-hex character checksum as defined in the NMEA specification, NMEA-0183Standard For Interfacing Marine Electronic Devices. Use of checksums is required on all input messages. 4. Each message is terminated using Carriage Return (CR) Line Feed (LF) which is \r\n which is hex 0D0A. Because \r\n are not printable ASCII characters, they are omitted from the example strings, but must be sent to terminate the message and cause the receiver to process that input message. 			

Table 5-2: Proprietary message parameters

Note: All fields in all proprietary NMEA messages are required, none are optional. All NMEA messages are comma delimited.

Table 5-3 shows the proprietary input message descriptions.

Message	MID*	Description
SetSerialPort	100	Set PORT A parameters and protocol
NavigationInitialization	101	Parameters required for start using X/Y/Z**
Query/Rate Control	103	Query standard NMEA message and/or set output rate
LLANavigationInitialization	104	Parameters required for start using Lat/Lon/Alt**
Development Data On/Off	105	Development Data messages On/Off
Select Datum	106	Selection of datum to be used for coordinate transformations
Get Navman SW Version	200	Poll software version information
Store Config-to-Flash	220	Store receiver configuration parameters to Flash
Trickle-Power Mode Configuration	221	Configure Trickle-Power mode
User Configuration	223	Set user configuration
*Message Identification (MID)		
**Input coordinates must be WGS84		

Table 5-3: Proprietary NMEA input messages

6.0 Product handling

6.1 Packaging and delivery

The MOQ (Minimum Order Quantity) for shipping is 100 units.

6.2 Safety

Improper handling and use of the Jupiter GPS receiver can cause permanent damage to the receiver and may even result in personal injury.

6.3 Disposal

This product should not be treated as household waste. For more detailed information about recycling of this product, please contact your local waste management authority or the seller from whom you purchased the product.

7.0 Ordering information

The part numbers of JS-3M are shown in Table 7.1. Minimum order quantity is 100 units.

Part Number	Configuration	Description
JS-3M	J3-ARS0-00-350.14	RS232 with Micro Battery, with LED

Table 7-1: Ordering information

8.0 Glossary and acronyms

2dRMS: twice-distance Root Mean Square

A horizontal measure of accuracy representing the radius of a circle within which the true value lies at least 95% of the time.

Almanac: A set of orbital parameters that allows calculation of approximate GPS satellite positions and velocities. The almanac is used by a GPS receiver to determine satellite visibility and as an aid during acquisition of GPS satellite signals. The almanac is a subset of satellite ephemeris data and is updated weekly by GPS Control.

C/A code: Course Acquisition code

A spread spectrum direct sequence code that is used primarily by commercial GPS receivers to determine the range to the transmitting GPS satellite.

C/N0: Carrier to Noise ratio

GDOP: Geometric Dilution of Precision

A factor used to describe the effect of the satellite geometry on the position and time accuracy of the GPS receiver solution. The lower the value of the GDOP parameter, the less the error in the position solution. Related indicators include PDOP, HDOP, TDOP and VDOP.

EGNOS: European Geostationary Navigation Overlay Service

The system of geostationary satellites and ground stations developed in Europe to improve the position and time calculation performed by the GPS receiver.

Ephemeris: A set of satellite orbital parameters that is used by a GPS receiver to calculate precise GPS satellite positions and velocities. The ephemeris is used to determine the navigation solution and is updated frequently to maintain the accuracy of GPS receivers.

GPS: Global Positioning System

A space-based radio positioning system that provides accurate position, velocity, and time data.

OEM: Original Equipment Manufacturer

Re-acquisition: The time taken for a position to be obtained after all satellites have been made invisible to the receiver.

SBAS: Satellite Based Augmentation System

Any system that uses a network of geostationary satellites and ground stations to improve the performance of a Global Navigation Satellite System (GNSS). Current examples are EGNOS and WAAS.

SRAM: Static Random Access Memory

SAW filter: Surface Acoustic Wave filter

WAAS: Wide Area Augmentation System

The system of satellites and ground stations developed by the FAA (Federal Aviation Administration) that provides GPS signal corrections. WAAS satellite coverage is currently only available in North America

JS-3M | Datasheet (Preliminary)

© 2011 Navman Wireless OEM. All Rights Reserved.

SiRF and SiRF logo are registered trademarks of SiRF Technology, Inc. SiRFstar, SiRFLoc, Push-to-Fix, and Trickle-Power are trademarks of SiRF Technology, Inc. All other trademarks mentioned in this document are property of their respective owners.

Information in this document is provided in connection with Navman Wireless OEM ('Navman') products. These materials are provided by Navman as a service to its customers and may be used for informational purposes only. Navman assumes no responsibility for errors or omissions in these materials. Navman may make changes to specifications and product descriptions at any time, without notice. Navman makes no commitment to update the information and shall have no responsibility whatsoever for conflicts or incompatibilities arising from future changes to its specifications and product descriptions. No license, express or implied, by estoppel or otherwise, to any intellectual property rights is granted by this document. Except as provided in Navman's Terms and Conditions of Sale for such products, Navman assumes no liability whatsoever.

THESE MATERIALS ARE PROVIDED 'AS IS' WITHOUT WARRANTY OF ANY KIND, EITHER EXPRESSED OR IMPLIED, RELATING TO SALE AND/OR USE OF NAVMAN PRODUCTS INCLUDING LIABILITY OR WARRANTIES RELATING TO FITNESS FOR A PARTICULAR PURPOSE, CONSEQUENTIAL OR INCIDENTAL DAMAGES, MERCHANTABILITY, OR INFRINGEMENT OF ANY PATENT, COPYRIGHT OR OTHER INTELLECTUAL PROPERTY RIGHT. NAVMAN FURTHER DOES NOT WARRANT THE ACCURACY OR COMPLETENESS OF THE INFORMATION, TEXT, GRAPHICS OR OTHER ITEMS CONTAINED WITHIN THESE MATERIALS. NAVMAN SHALL NOT BE LIABLE FOR ANY SPECIAL, INDIRECT, INCIDENTAL, OR CONSEQUENTIAL DAMAGES, INCLUDING WITHOUT LIMITATION, LOST REVENUES OR LOST PROFITS, WHICH MAY RESULT FROM THE USE OF THESE MATERIALS.

Navman products are not intended for use in medical, lifesaving or life sustaining applications. Navman customers using or selling Navman products for use in such applications do so at their own risk and agree to fully indemnify Navman for any damages resulting from such improper use or sale. Product names or services listed in this publication are for identification purposes only, and may be trademarks of third parties. Third-party brands and names are the property of their respective owners. Additional information, posted at www.navmanwirelessoem.com, is incorporated by reference. Reader response: Navman strives to produce quality documentation and welcomes your feedback. Please send comments and suggestions to Americastechsupport@navmanwirelessoem.com. For technical questions, contact your local Navman sales office or field applications engineer.

PRELIMINARY
CONFIDENTIAL



Revision History

Date	Revision	Changes
July 17, 11	C	Environmental

PRELIMINARY
CONFIDENTIAL