

C-1-1105851-8

PASSMASS	ABMASS

PROJECT NO. -

USED ON HTS

# HTS - HAND TOOL FOR HN.D, HE/HA AND HVT CONTACTS 0,14 - 4,0 mm<sup>2</sup>

THIS DRAWING IS A CONTROLLED DOCUMENT FOR THE MANUFACTURING AND THE CONTROLLING ENGINEERING ORGANIZATION AND SHOULD BE CONTACTED FOR THE LATEST REVISION.

DIESES ZEICHNUNGSDOKUMENT WIRD DURCH AMP INCORPORATED KONTROLLIERT. AENDERUNGEN, DIE DEM TECHNISCHEN FORTSCHRITTSSTAND ENTSPRECHEN, SIND VORBEHALTEN. DEN JEWELIGEN LETZTLIEFENDEN AENDERUNGSSTAND ERFAHREN SIE AUF ANFRAGE.

THIS INFORMATION IS CONFIDENTIAL AND IS SO LOGGED TO BE KEPT AS SUCH. IT IS TO BE KEPT CONFIDENTIAL BY YOU TO OTHER THAN AMP PERSONNEL WITHOUT WRITTEN AUTHORIZATION FROM AMP INCORPORATED, © - 2002 AMP

Querschnittgröße Wire Size mm <sup>2</sup>	Kontakttyp und TE P/N Contact type and TE P/N		
	HN.D	HE/HA	HVT
0,13 - 0,40			6-1105300-1 6-1105300-2 6-1105301-1 6-1105301-2
0,14		6-1105100-1 6-1105101-1	
0,14 - 0,37	1-1105050-1 1-1105050-2 1-1105051-1 1-1105051-2		
0,5	2-1105050-1 2-1105050-2 2-1105051-1 2-1105051-2	1-1105100-1 1-1105100-2 1-1105101-1 1-1105101-2	1-1105300-1 1-1105300-2 1-1105301-1 1-1105301-2
0,75 - 1,0	3-1105050-1 3-1105050-2 3-1105051-1 3-1105051-2	2-1105100-1 2-1105100-2 2-1105101-1 2-1105101-2	2-1105300-1 2-1105300-2 2-1105301-1 2-1105301-2
1,5	4-1105050-1 4-1105050-2 4-1105051-1 4-1105051-2	3-1105100-1 3-1105100-2 3-1105101-1 3-1105101-2	3-1105300-1 3-1105300-2 3-1105301-1 3-1105301-2
2,5	5-1105050-1 5-1105050-2 5-1105051-1 5-1105051-2	4-1105100-1 4-1105100-2 4-1105101-1 4-1105101-2	4-1105300-1 4-1105300-2 4-1105301-1 4-1105301-2
4,0		5-1105100-1 5-1105100-2 5-1105101-1 5-1105101-2	5-1105300-1 5-1105300-2 5-1105301-1 5-1105301-2

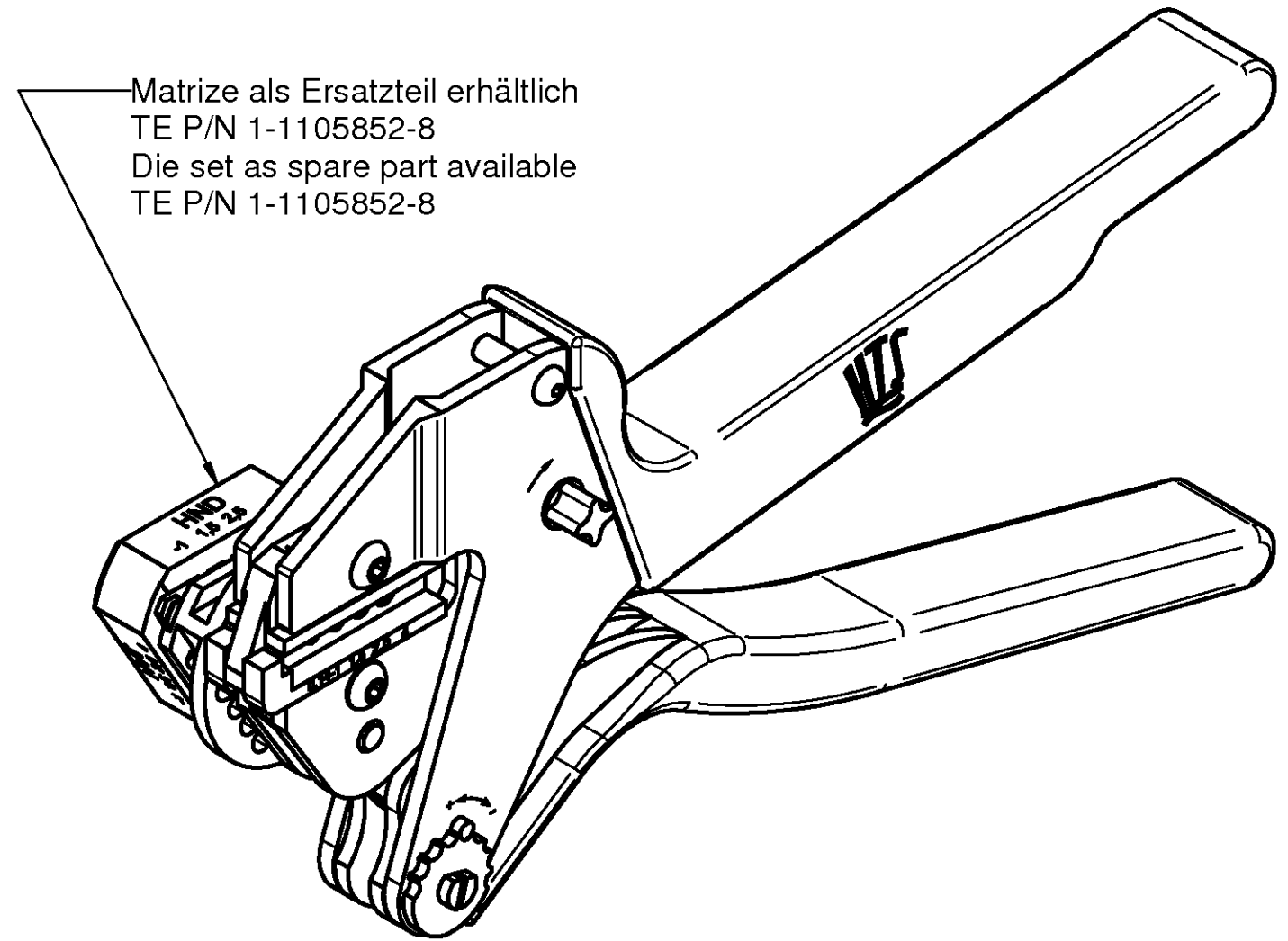

Handzange mit Matrize zusammengebaut und mit Bedienungsanleitung 411-18501 im Karton verpackt  
Hand Tool assembled with die set and packed in a cardboard with instruction sheet 411-18501

FREI-MASSTOLERANZEN NACH DIN 7168 (WERTE IN mm)							
1) ABWEICHEND VON DIN 7168 2) LÄNGE DES KÜRZEREN SOHNKELS							
NENNMASS- BEREICH 1)	UBER	0,5	3	6	30	120	400
BIS	3	6	30	120	400	1000	
LÄNGEN- ABMASSE	MITTEL	± 0,1	± 0,1	± 0,2	± 0,3	± 0,5	± 0,8
MASSE		± 0,2	± 0,5	± 1	± 2	± 4	± 4
RADIEN U. FASEN		± 1'	± 1'	± 30'	± 20'	± 10'	± 5'
WINKELABMASSE 1) 2)							

GENERAL TOLERANCES ACC. TO DIN 7168 (VALUES IN mm)							
1) DEVIATING FROM DIN 7168 2) LENGTH OF SHORT ANGLE SIDE							
TEIL IM BEREICH X_ MIT PN-STRICH-NR. (-1 WIE GEZ.), REVISION-STAND UND LIEFERANTENS YMBOL GEKENNZEICHNET							
PART TO BE MARKED WITH PN-DASH NO. (-1 AS SHOWN), REV. STATUS AND VENDORS MARK IN AREA X_							
OBERFLÄCHENVERGLEICHSTABELLE							
DIN 3141 R3							
R <sub>a</sub> in µm	6,3	1,6	0,4	0,1			
DIN ISO 1302	✓	✓	✓	✓			
ALLE UNBEMASSTE KANTEN 0,2x45° ENTGRÄTET REMOVE BURRS, BREAK SHARP EDGES 0,2x45°							
BOHRG- OHNE ANGABE							
HOLE NOT SPEC							
P	LTR	REVISION RECORD	DATE	DWN	APVD		

FINISH	-
DIMENSIONS	mm
TOLERANCES UNLESS OTHERWISE SPECIFIED:	n. ISO 2815 n. ISO 2768 n. DIN 16901 :
ANGLES	0 PLC ± 1 PLC ± 2 PLC ± 3 PLC ± 4 PLC ±
SURFACE TEXTURE	

DWN	23.09.2008 P. Demmer
CHK	23.09.2008 Ch. Witt
APVD	23.09.2008 Ch. Witt
NAME	HTS - HAND TOOL FOR HN.D, HE/HA AND HVT CONTACTS HTS - Handzange für HN.D, HE/HA und HVT Kontakte
SCALE	1:1
SIZE	A3
DRAWING NO	C-1-1105851-8

MATERIAL	-	Gewicht / Weight in Kg	0,935
HEAT TREAT	-		
Tyco Electronics AMP GmbH 64625 Bensheim (Germany)			
SCALE	1:1	SIZE	A3
DRAWING NO	C-1-1105851-8	SHEET	1 OF 1
REV	A		

AMP 3306-7 REV 23FEB95

8

7

6

5

4

3

2

1