

**PROPER USE GUIDELINES**

Cumulative Trauma Disorders can result from the prolonged use of manually powered hand tools. Hand tools are intended for occasional use and low volume applications. A wide selection of powered application equipment for extended-use, production operations is available.

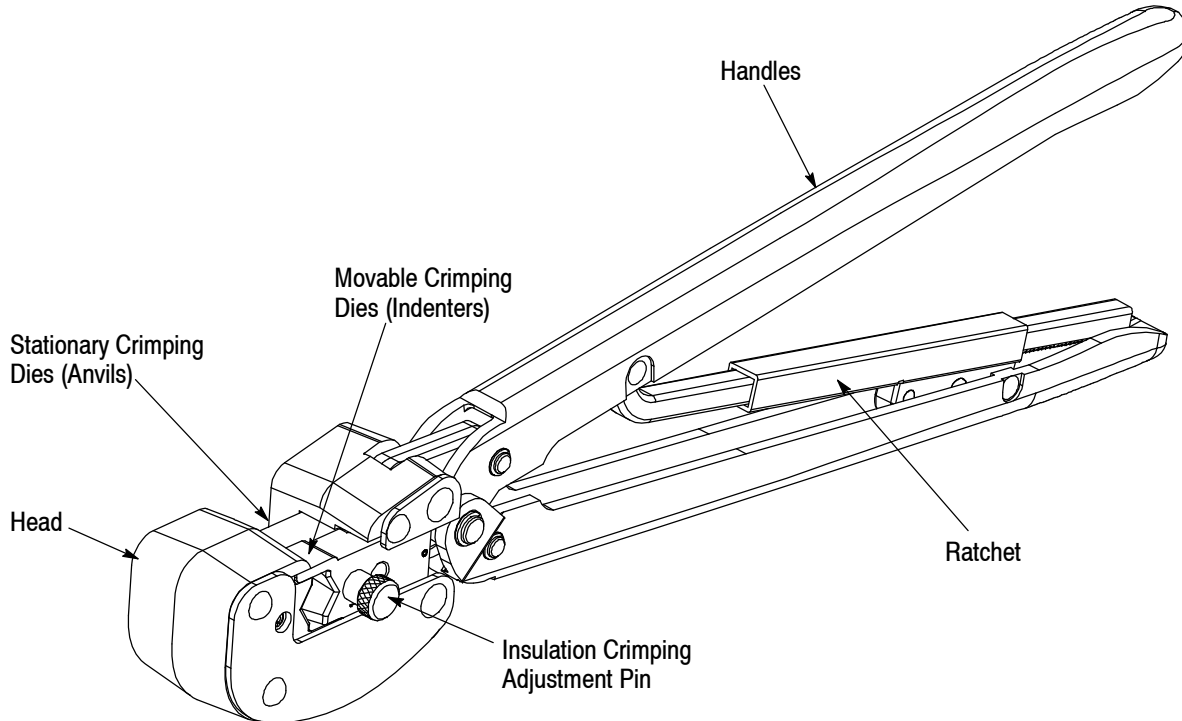

PRODUCT		WIRE				
PRODUCT TYPE	TERMINAL (and TOOL) COLOR CODE	MINIMUM STRIP LENGTH	MAXIMUM STRIP LENGTH	TYPE	SIZE (AWG)	MAX INS DIAMETER
AMPLI-BOND*	Red	12.7 [.50]	13.4 [.53]	Stranded Copper	8	9.58 [.377]
PLASTI-GRIP*		8.6 [.34]	9.4 [.38]		8	9.906 [.390]

Figure 1

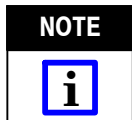

*Dimensions in this instruction sheet are in millimeters [with inches in brackets]. Figures are not drawn to scale.*

(indenters), an insulation crimping adjustment pin, and handles with a ratchet. See Figure 1.

**1. INTRODUCTION**

Large Expansion Insulation Crimp Heavy Head Hand Crimping Tool 69959-1 was designed to crimp the product listed in Figure 1 onto the wire also listed.

These tools are members of the CERTI-CRIMP\* hand crimping tool family. The ratchet on these tools ensures full crimping of the product. Once engaged, the ratchet will not release until the handles have been FULLY closed.

**2. DESCRIPTION**

Each tool consists of a head containing two stationary crimping dies (anvils) and two movable crimping dies

When closed, the crimping dies form a crimping chamber with two sections: an insulation barrel section and a wire barrel section. The insulation barrel section crimps the insulation barrel of the product onto the wire insulation and, simultaneously, the wire barrel section crimps the wire barrel of the product onto the wire conductors.

**CAUTION** *The crimping dies bottom before the ratchet releases. This design ensures maximum electrical and tensile performance of the crimp. DO NOT re-adjust the ratchet.*

### 3. CRIMPING PROCEDURE

#### 3.1. Wire Preparation

Strip the wire to the dimensions given in Figure 1, being careful to avoid nicking or damaging the wire conductors.

**NOTE** *DO NOT use wire with nicked or missing conductors.*

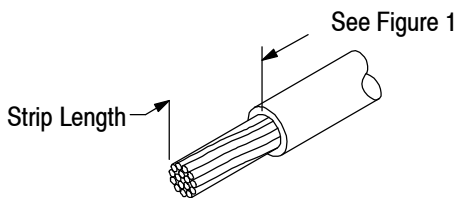

#### 3.2. Crimping

**NOTE** *Make sure that the insulation color code of the product matches the color of the tool. Refer to Figure 1.*



**NOTE** *See Section 4 for insulation adjustment procedures.*



1. Place the insulation crimping adjustment pin in the number two (loose) position. See Figure 1.
2. Open the crimping dies by closing the tool handles until the ratchet releases, then allow the handles to open FULLY.
3. Place the terminal in the crimping chamber so that the bottom of the tongue faces the top of the tool and the wire barrel butts against the locator. Refer to Figure 2.
4. Close the tool handles until the terminal is held firmly in place. DO NOT deform the terminal.
5. Insert a properly stripped wire into the terminal wire barrel until the end of the wire conductors butt against the locator.

**NOTE** *DO NOT allow the wire insulation to enter the terminal wire barrel.*



6. Complete the crimp by closing the tool handles until the ratchet releases.
7. Release the tool handles, allow the handles to open FULLY, and remove the crimped terminal.
8. Inspect the crimp to make sure that it conforms to Figure 3. Terminals not meeting the described conditions should NOT be used.

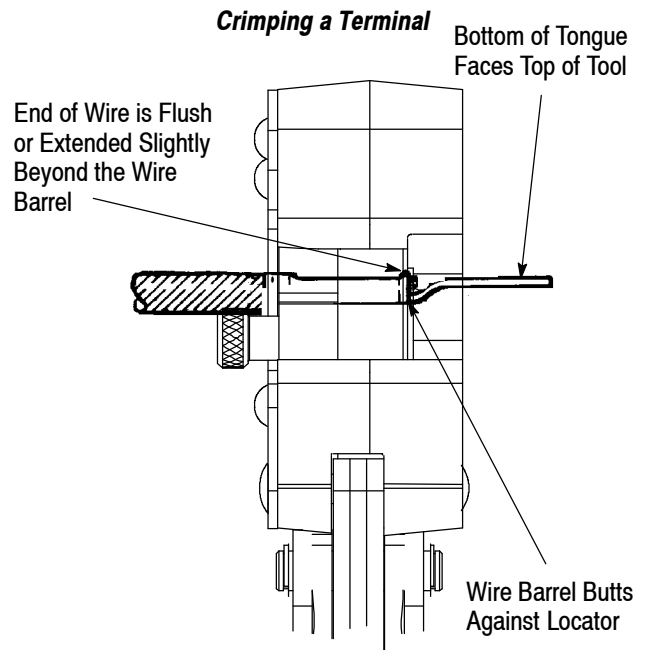

Figure 2

### 4. INSULATION CRIMP ADJUSTMENT

The insulation crimping section of the hand tool has two positions: 1 (tight), and 2 (loose). To adjust the grip resulting from the crimp of the insulation barrel, proceed as follows:

**NOTE** *AMPLI-BOND terminals feature a wire insulation "grip." PLASTI-GRIP terminals feature a wire "insulation support."*

1. Place the insulation adjustment pin in the No 2 (loose) position.
2. Make a test crimp.
3. Remove the crimped terminal and visually inspect the insulation barrel crimp.
  - a. On AMPLI-BOND terminals the insulation barrel should provide a "grip" on the wire insulation.
  - b. On PLASTI-GRIP terminals the insulation barrel should provide support for the wire insulation

4. If the grip needs to be increased, move the pin to the No.1 position.
5. Repeat the crimp over the previously crimped terminal.

6. Check the insulation barrel crimp by bending the wire back and forth. The terminal should retain its grip/support on the insulation. Inspect the crimp according to Figure 3.

**Accept**

**Crimp Inspection of  
AMPLI-BOND and  
PLASTI-GRIP Terminals**

**Reject**

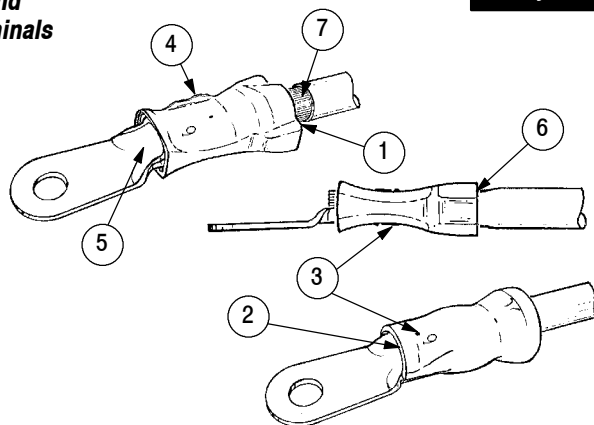
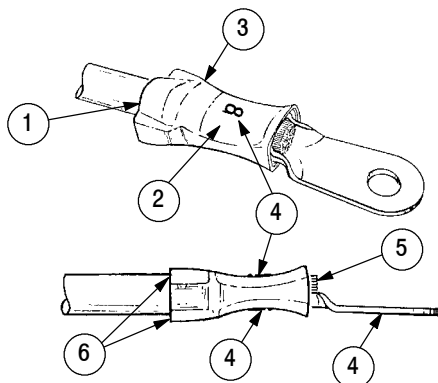

- 1 Wire fully inserted.
- 2 Correct color code and die combination.
- 3 Crimp centered on wire barrel.
- 4 Wire size being used is same as wire size embossed on terminal insulation and stamped on terminal tongue.
- 5 End of conductor (i.e., brush) is flush with or extends beyond end of wire barrel of terminal.
- 6 Insulation barrel is in contact with wire insulation. (AMPLI-BOND terminals have insulation "grip" and PLASTI-GRIP terminals have insulation "support".)

- 1 Wire not fully inserted.
- 2 Crimp not centered on wire barrel.
- 3 Wrong die and terminal code (NOT number 8). See Figure 1.
- 4 Excessive flash or extruded insulation. (Wrong size or damaged dies.)
- 5 End of conductor (i.e., brush) is not flush with or extending beyond end of wire barrel of terminal.
- 6 Wire insulation pinched. (Insulation crimp too tight on AMPLI-BOND terminals.)
- 7 Nicked or missing conductor strands.

Figure 3

## 5. MAINTENANCE AND INSPECTION

It is recommended that a maintenance and inspection program be performed periodically to ensure dependable and uniform terminations. Though recommendations call for at least one inspection a month, frequency of inspection depends on:

1. The care, amount of use, and handling of the tool.
2. The presence of abnormal amounts of dust and dirt.
3. The degree of operator skill.
4. Your own established standards.

The tool is inspected before being shipped; however, it is recommended that the tool be inspected immediately upon arrival to ensure that the tool has not been damaged during shipment.

### 5.1. Daily Maintenance

1. Immersed the tool (handles partially closed) in a reliable commercial degreasing compound to remove accumulated dirt, grease, and foreign matter. When degreasing compound is not available, the tool may be wiped clean with a soft, lint-free cloth. DO NOT use hard or abrasive objects that could damage the tool.
2. Make certain that the retaining pins are in place and that they are secured with retaining rings.
3. All pins, pivot points, and bearing surfaces should be protected with a THIN coat of any good SAE 20 motor oil. DO NOT oil excessively.
4. When the tool is not in use, keep the handles closed to prevent objects from becoming lodged in the crimping dies. Store the tool in a clean, dry area.

### 5.2. Periodic Inspection

#### A. Lubrication

Lubricate all pins, pivot points, and bearing surfaces with any good SAE 20 motor oil as follows:

- Tool used in daily production — daily
- Tool used daily (occasional) — weekly
- Tool used weekly — monthly

Wipe excess oil from the tool, particularly from the crimping area. Oil transferred from the crimping area onto certain terminations may affect the electrical characteristics of an application.

#### B. Visual Inspection

1. Close the tool handles until the ratchet releases and then allow them to open freely. If they do not open quickly and fully, the spring is defective and must be replaced. See Section 6, REPLACEMENT AND REPAIR.
2. Inspect the head for worn, cracked, or broken crimping dies. See Figure 4. If damage is evident, return the tool for evaluation and repair. See Section 6, REPLACEMENT AND REPAIR.

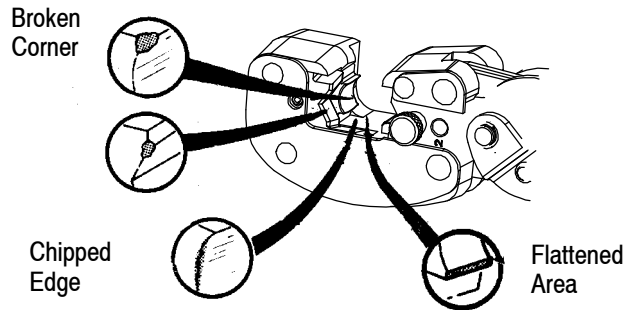



Figure 4

#### C. Gaging the Crimping Chamber

This inspection requires the use of plug gages conforming to the dimensions provided in Figure 5. To gage the crimping chamber, proceed as follows:

<b>NOTE</b>	<p><i>If gaging the crimping chamber is not required, inspect the die closure using an alternate procedure, i.e., the "Insulation Crimp Adjustment" (see Section 4) and "Visual Inspection" (see Paragraph 5.2.B).</i></p>
	

1. Remove traces of oil or dirt from the crimping chamber and plug gage.
2. Insert each insulation crimp adjustment pin into Position No. 2. See Figure 6.
3. Close the tool handles until the crimping dies bottom, and hold in this position. DO NOT force beyond initial contact.
4. Press and hold the locator down.
5. Carefully insert the GO element into the crimping chamber as shown in Figure 6; DO NOT force it. For the wire barrel section of the crimping chamber, the GO element must pass completely through the crimping chamber. For the insulation barrel section, the GO element must pass through the length of the section but will stop against the wire barrel section.
6. In the same manner, try to insert the NO-GO element into the crimping chamber as shown in Figure 6. The NO-GO element may begin entry, but may not pass through the crimping chamber.

Wire Barrel Section of Crimping Chamber

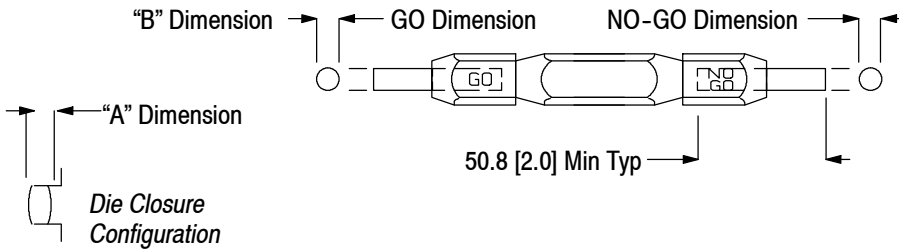

SUGGESTED PLUG GAGE DESIGN -- WIRE BARREL CRIMP

DIE CLOSURE DIMENSION "A" (Set Adjustment Pin in No. 2 Position)		GAGE MEMBER DIMENSION "B"	
GO	NO-GO	GO	NO-GO
5.105 [.2010]	5.258 [.2070]	5.105-5.113 [.2010-.2013]	5.258-5.257 [.2069-.2070]

Insulation Barrel Section of Crimping Chamber

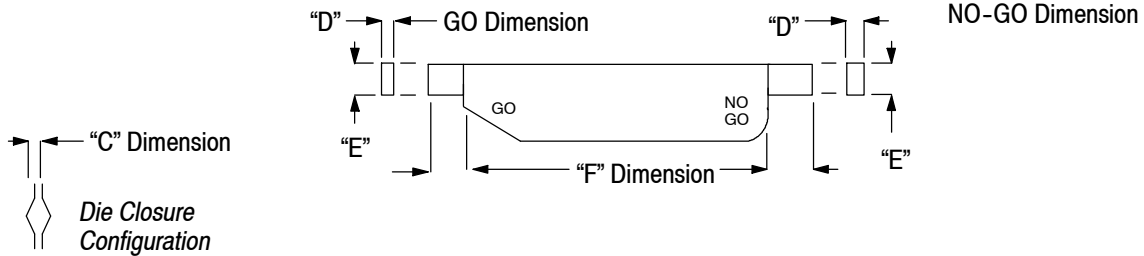

SUGGESTED PLUG GAGE DESIGN -- LARGE EXPANSION INSULATION CRIMP

DIE CLOSURE DIMENSION "C" (Set Adjustment Pin in No. 1 Position)		GAGE MEMBER DIMENSIONS			
		WIDTH "D"		WIDTH "E"	"F" DIMENSION
GO	NO-GO	GO	NO-GO	7.137 [.281]	6.35 [.25]
4.216 [.1660]	4.724 [.1860]	4.216-4.224 [.1660-1663]	4.721-4.724 [.1859-.1860]		

Figure 5

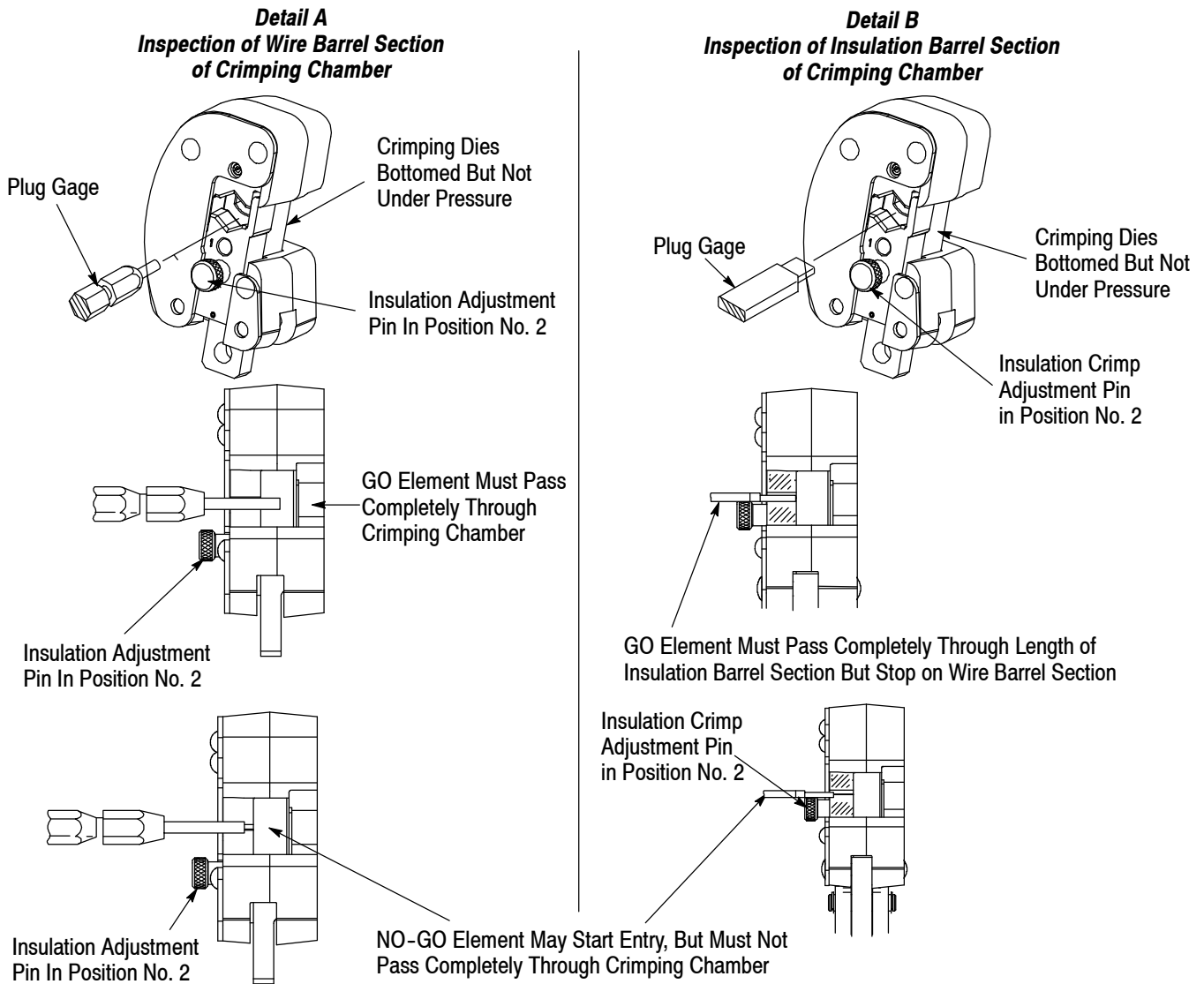

Figure 6

If the crimping chamber conforms to the gage inspection, the tool is considered dimensionally correct, and should be lubricated with a THIN coat of any good SAE 20 motor oil. If not, return the tool for evaluation and repair. See Section 6, REPLACEMENT AND REPAIR.

### 5.3. Ratchet Inspection

Check the ratchet to ensure that the ratchet does not release prematurely, allowing the dies to open before they have fully bottomed. Proceed as follows:

1. Remove traces of oil or dirt from the bottoming surfaces of the dies.
2. Obtain a 0.025 [.001] shim that is suitable for checking the clearance between the bottoming surfaces of the dies.

3. Select a terminal or splice and *maximum* size wire for the terminal or splice.

4. Position the terminal or splice in the crimping chamber according to Section 3, CRIMPING PROCEDURE. Holding the wire in place, squeeze the tool handles together until the ratchet releases. Hold the tool handles in this position, maintaining just enough pressure to keep the dies closed.

5. Check the clearance between the bottoming surfaces of the dies. If the clearance is 0.025 [.001] or less, the ratchet is satisfactory. If clearance exceeds 0.025 [.001], the ratchet is out of adjustment and must be repaired. See Section 6, REPLACEMENT AND REPAIR.

For customer repair service, call 1-800-526-5136.

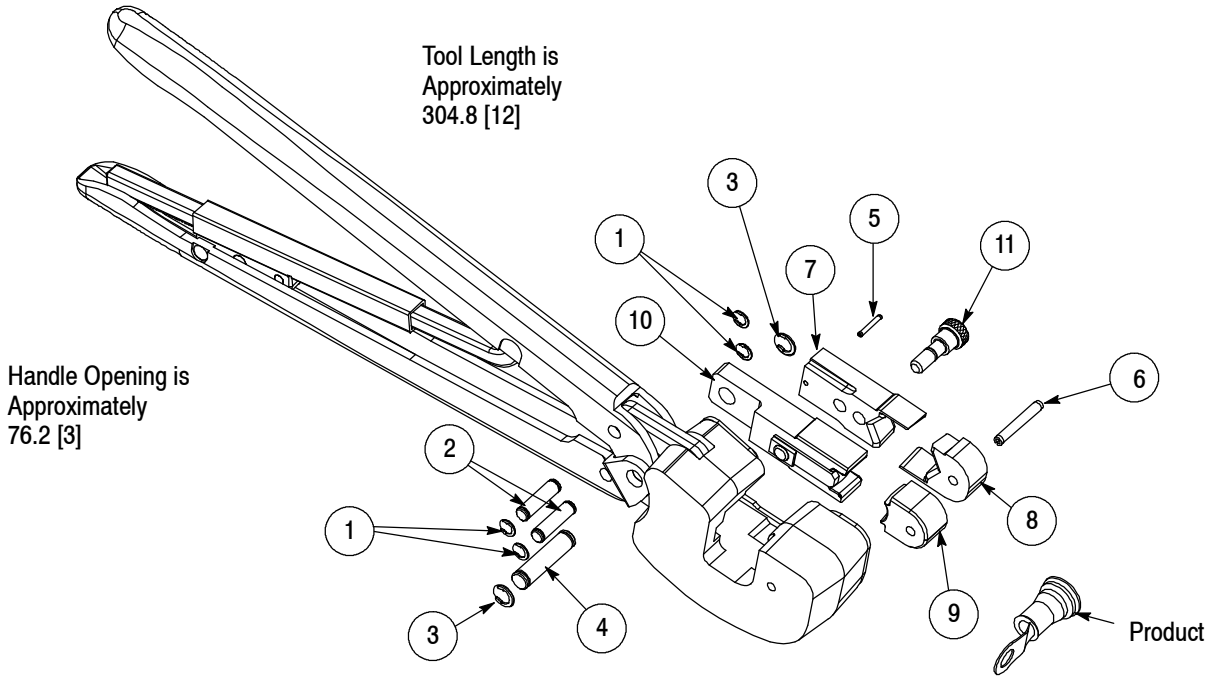

**REPLACEMENT PARTS**

ITEM	PART NUMBER	DESCRIPTION	QTY PER TOOL
1	21045-3	RING, Retaining	4
2	300388	PIN, Retaining	2
3	21045-6	RING, Retaining	2
4	300389	PIN, Retaining	1
5	21028-5	PIN	1
6	6-21028-1	PIN	1
7	--	MOVING DIE, Insulation	1
8	--	STATIONARY DIE, Insulation	1
9	--	STATIONARY DIE, Wire Barrel	1
10	--	MOVING DIE ASSEMBLY, Wire Barrel	1
11	303848-2	PIN, Adjustment	1

Figure 7

**6. REPLACEMENT AND REPAIR**

Customer-replaceable parts are listed in Figure 7. A complete inventory should be stocked and controlled to prevent lost time when replacement of parts is necessary. Parts other than those listed should be replaced by TE Connectivity to ensure quality and reliability. Order replacement parts through your representative, or call 1-800-526-5142, or send a facsimile of your purchase order to 717-986-7605, or write to:

CUSTOMER SERVICE (038-035)  
 TYCO ELECTRONICS CORPORATION  
 PO BOX 3608  
 HARRISBURG PA 17105-3608

**7. REVISION SUMMARY**

Since the previous version of this document, the following changes were made:

- Updated document to corporate requirements.