

PRODUCT NUMBER	HSG&FRAME COLOR
10130812-101LF	BLACK

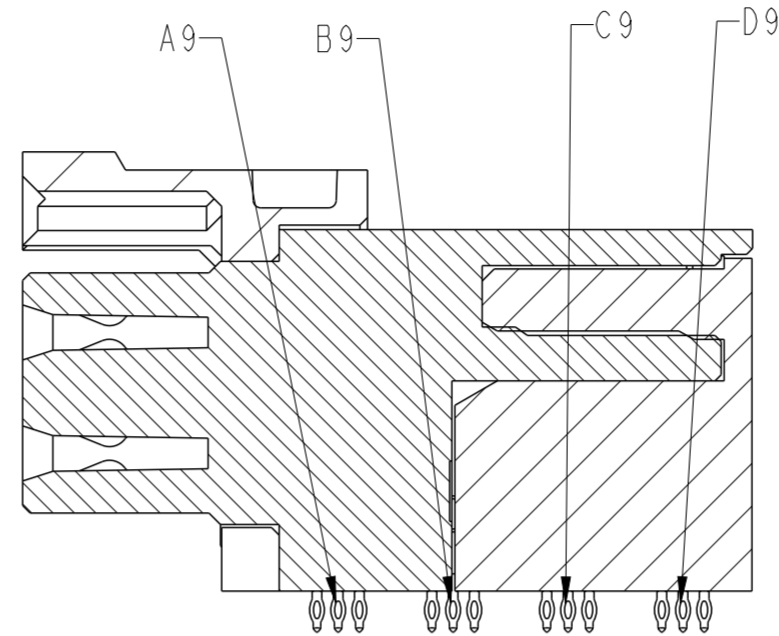

SECTION Z-Z

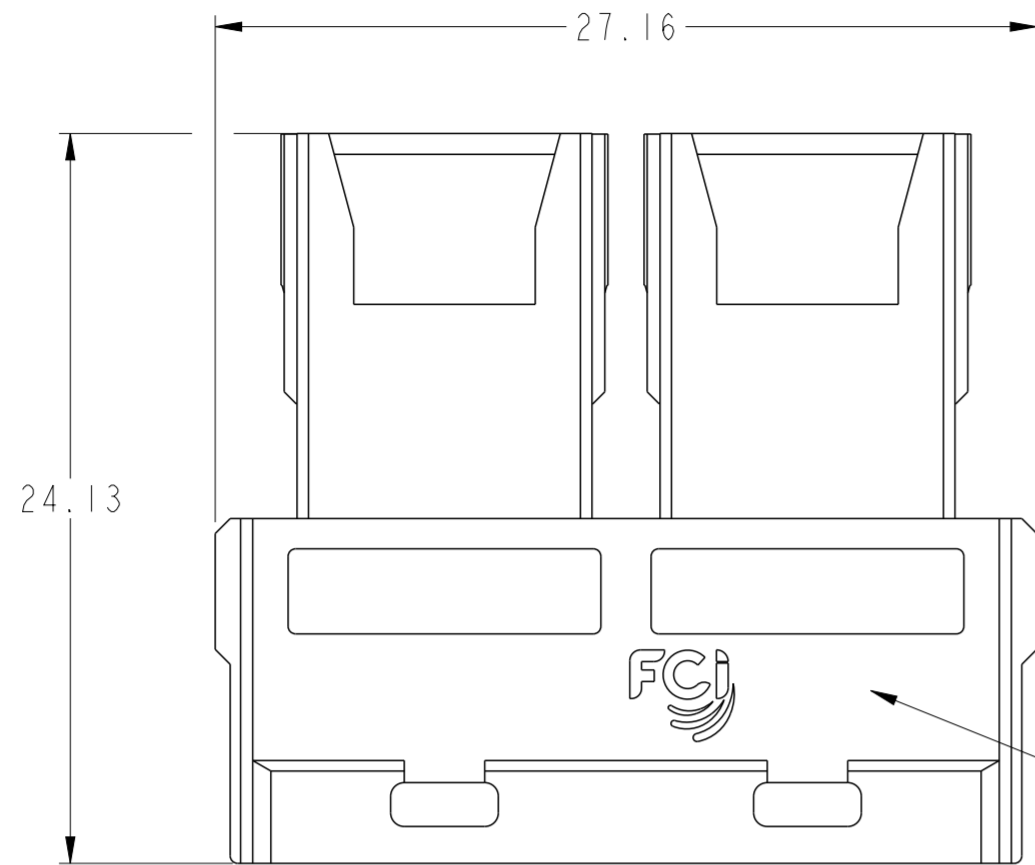
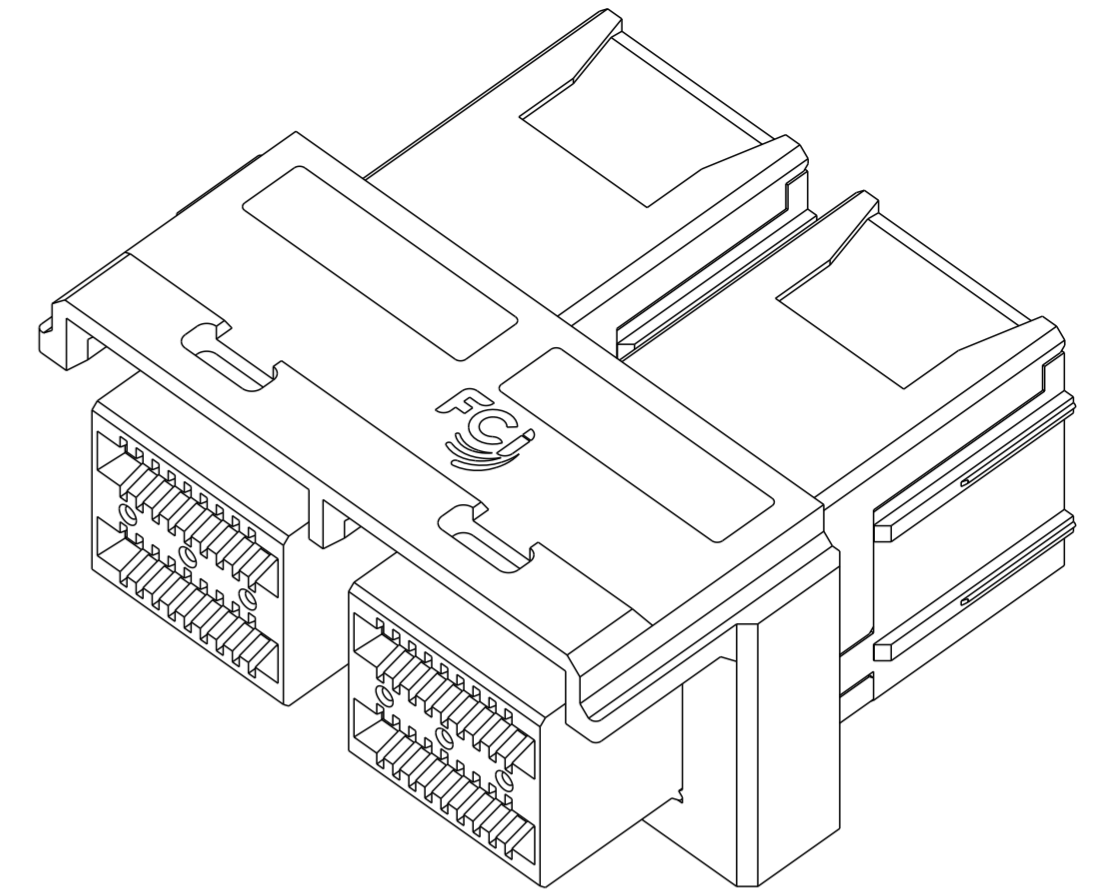

FCI P/N AND DATE CODE ON THIS SURFACE

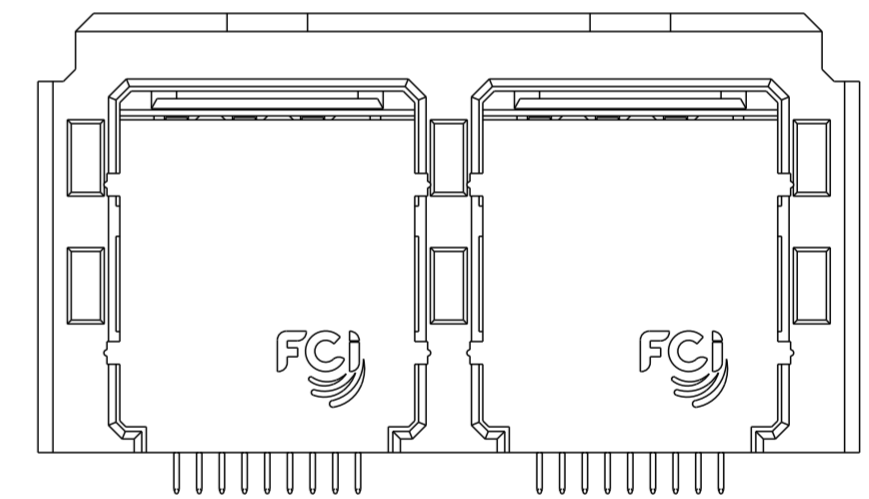
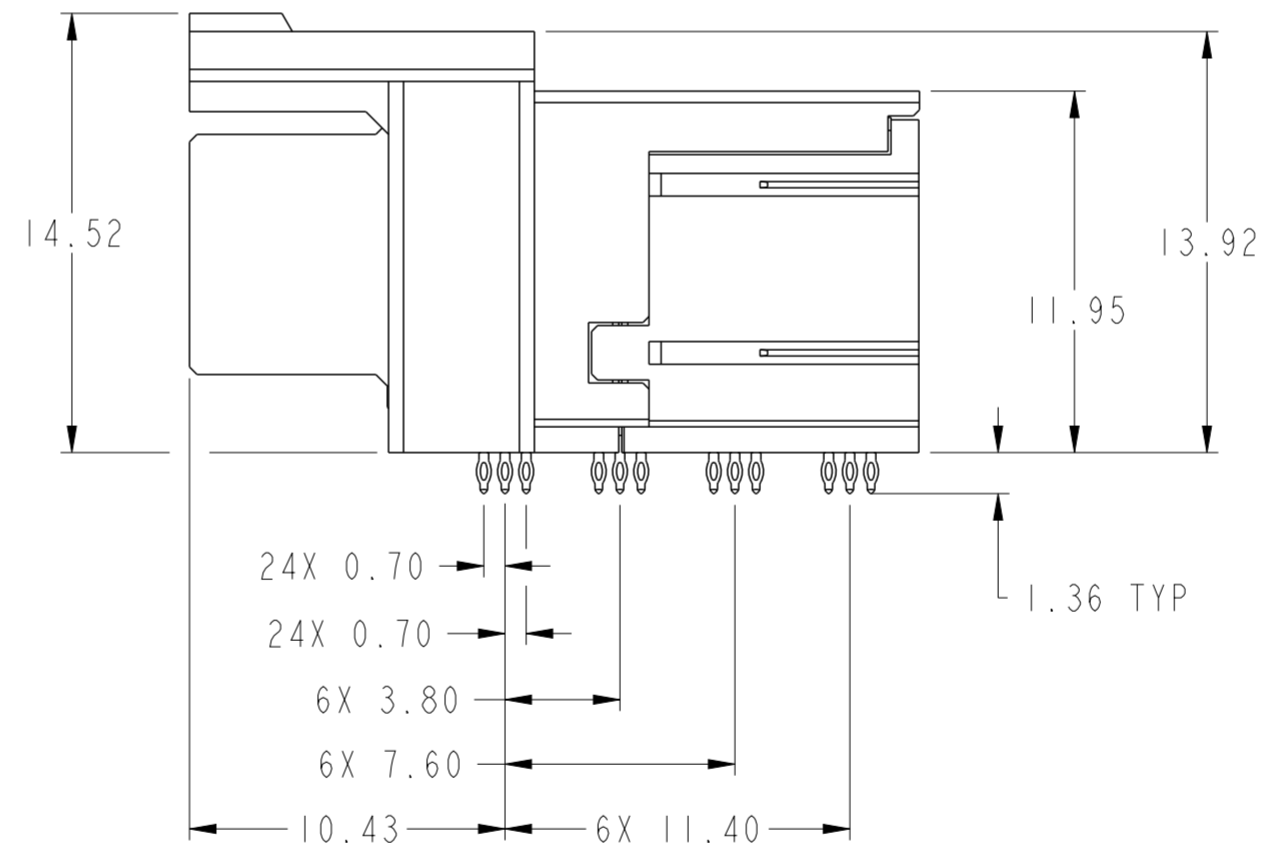
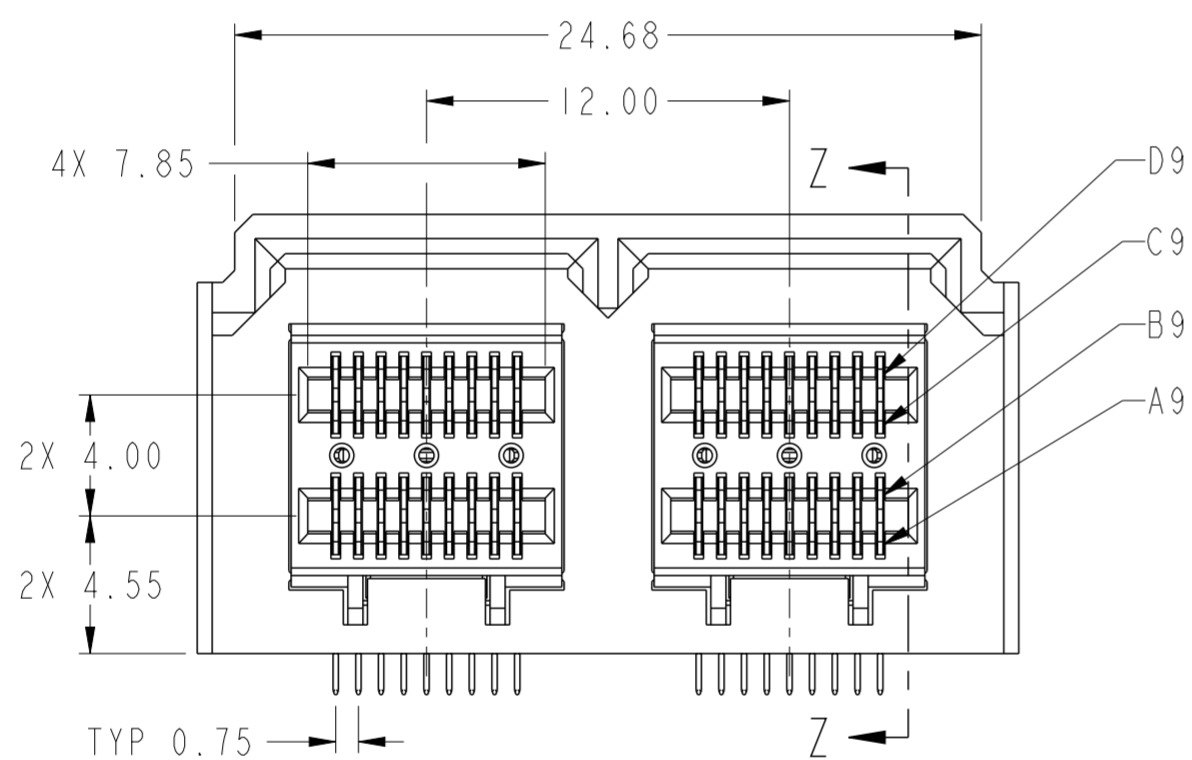

NOTES:

- MATERIALS:  
CONNECTOR HOUSING: HIGH TEMPERATURE THERMOPLASTIC  
GLASS FILLED, UL 94V-0  
TERMINALS: COPPER ALLOY
- FINISHES:  
CONTACT AREA: 0.76µm GOLD OVER 2.54µm NICKEL  
CONTACT TAIL AREA: 0.76µm - 1.52µm TIN OVER 2.54µm NICKEL.
- PRODUCT SPECIFICATION: GS-12-650.  
APPLICATION SPECIFICATION: GS-20-0356
- RECOMMENDED MOUNTING HARDWARE:  
OPTION 1: M2 X 0.40mm SELF-THREADING SCREW  
OPTION 2: M2 X 0.80mm SELF-THREADING SCREW  
OPTION 3: M2 X 0.91mm SELF-THREADING SCREW  
RECOMMENDED MOUNTING SCREW LENGTH: PCB THICKNESS + 2.5±0.35mm.
- THIS CONNECTOR IS DESIGNED TO MEET THE REQUIREMENTS OF INDUSTRY SPECIFICATION SFF-8643.
- A  $\Delta$  SYMBOL WILL BE NEXT TO ANY DIMENSION, VIEW, OR NOTE THAT HAS BEEN MODIFIED WITH THE CURRENT DRAWING REVISION.

MATES WITH MINI-SAS HD ENDS IN:
10119217 SERIES (4i)
10119312 SERIES (4i)
10120086 SERIES (4i)
10120087 SERIES (4i)
10119576 SERIES (8i)
10119577 SERIES (8i)
10120088 SERIES (8i)
10120089 SERIES (8i)

spec ref	-	dr	Jackbin Zou	2014/07/07	projection	MM	size	A2	scale	4:1
tolerance std	ASME Y14.5	eng	Jackbin Zou	2014/12/18	chr	-	ecn no	-	rel level	Released
surface	linear	0.X	±0.35	0.XX	±0.25	0.XXX	±	angular	0°	±2°
TOLERANCES UNLESS OTHERWISE SPECIFIED		FCI		title		IX2 INTERNAL ASSEMBLY		MINI-SAS HD		cat. no.
www.fci.com		Product - Customer Drw		sheet 1 of 4		10130812		rev		A

# RECOMMENDED PC BOARD LAYOUT

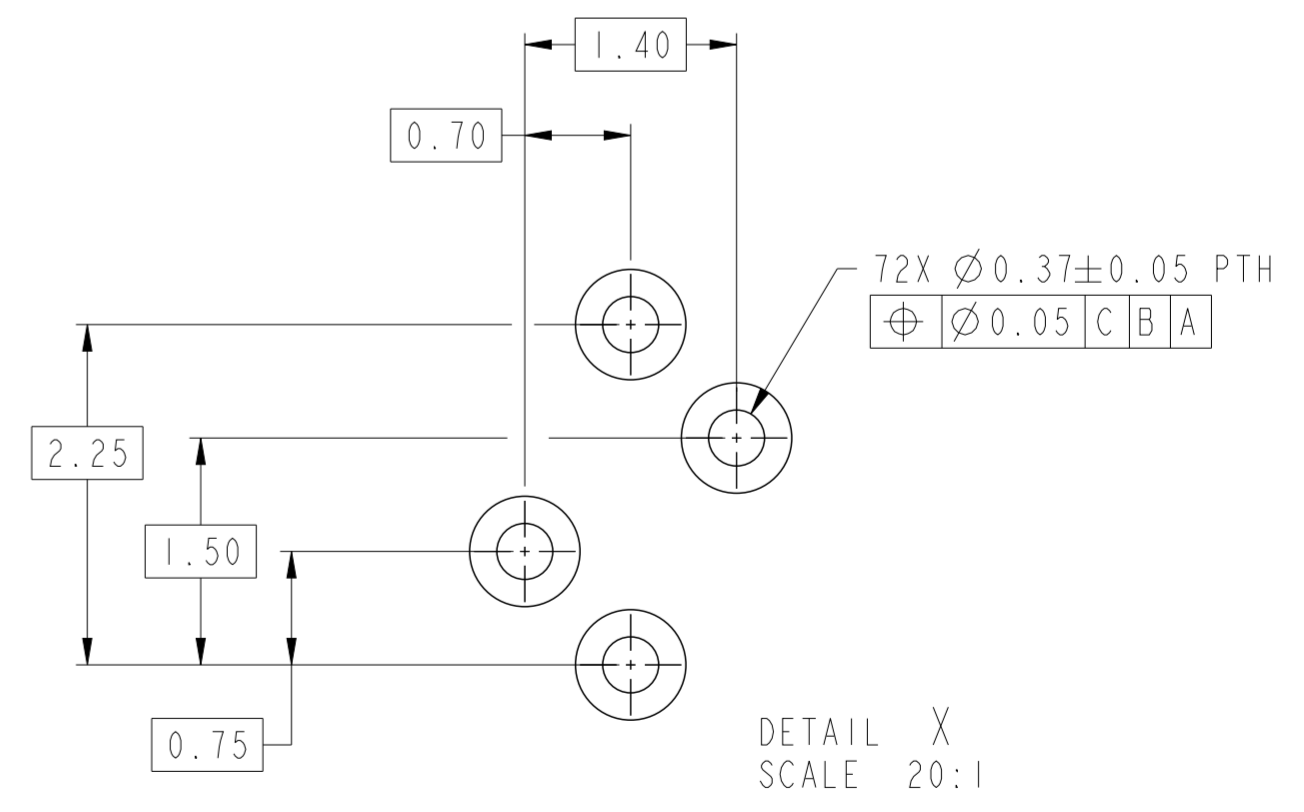
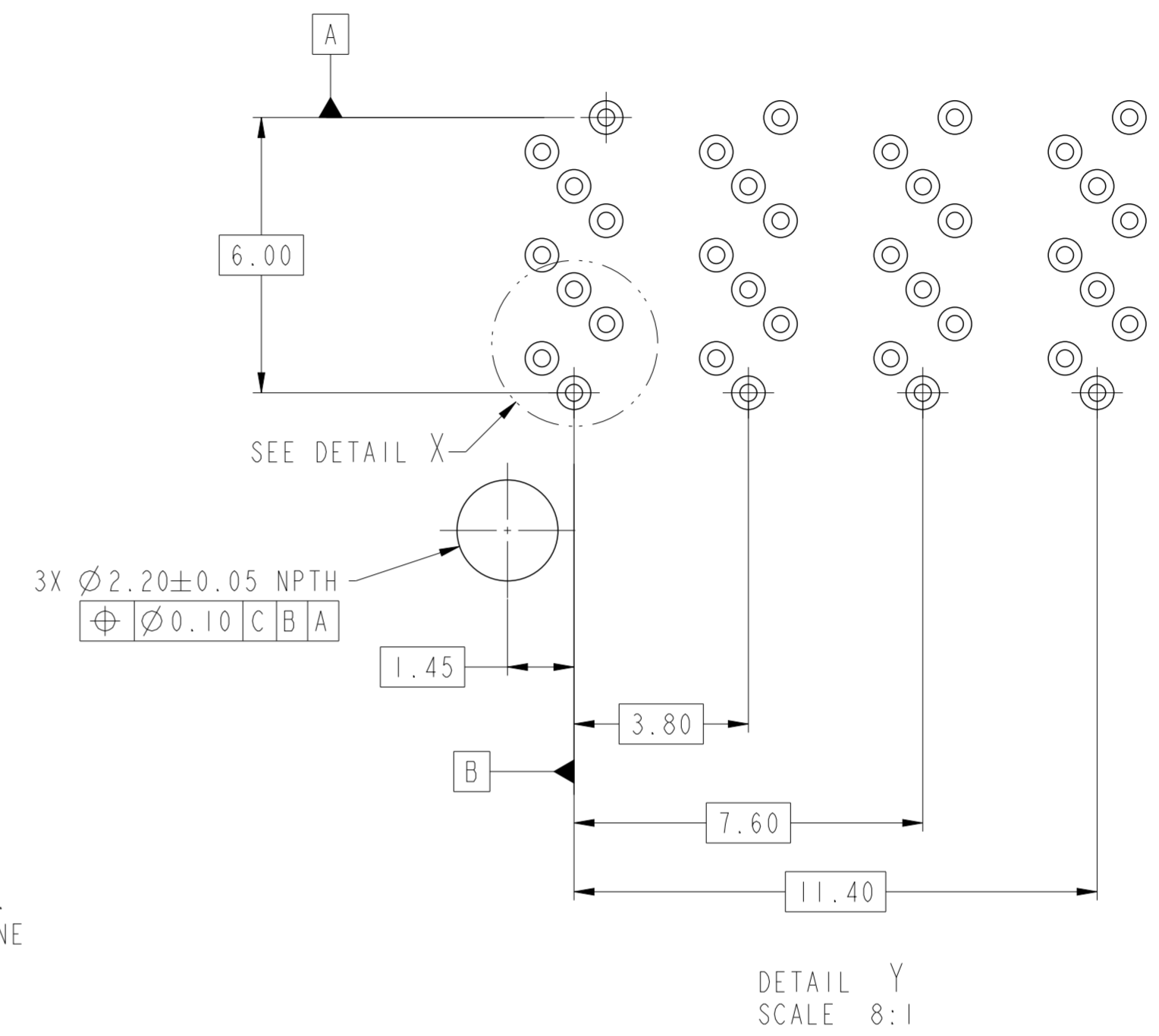
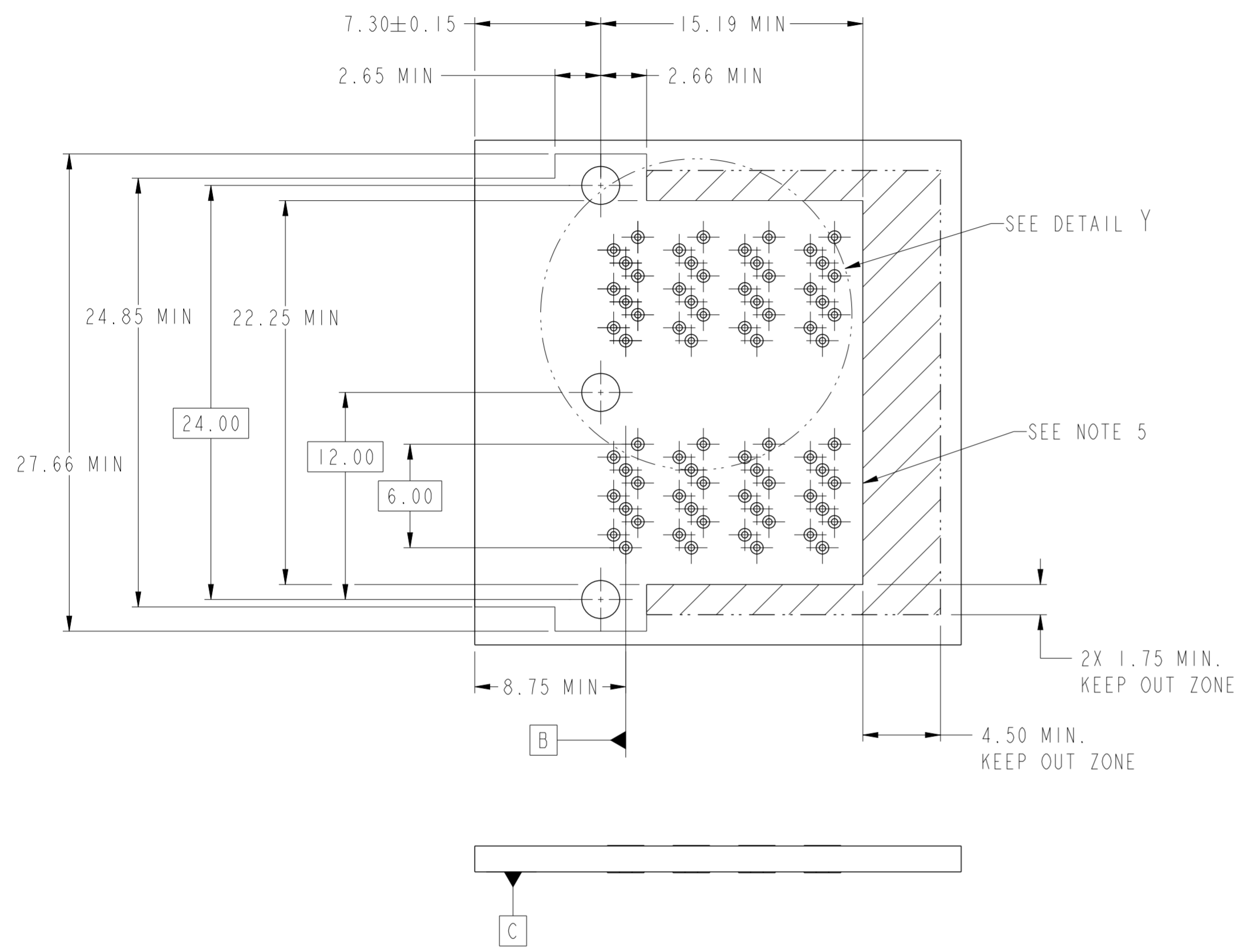

## NOTES:

1. RECOMMENDED DRILL SIZE FOR A Ø0.37 FINISHED PTH IS Ø0.457(#77 DRILL).
2. RECOMMENDED ANNULAR RING AROUND Ø0.37 FINISHED PTH IS Ø0.73.
3. MINIMUM RECOMMENDED SPACING : 14.00mm.
4. MINIMUM PCB THICKNESS : 1.57mm.
5. CONNECTOR KEEP OUT AREA.

spec ref	-	dr	Jackbin Zou	2014/07/07	projection	MM	size	A2	scale	2:1
tolerance std	ASME Y14.5	eng	Jackbin Zou	2014/12/18	chr	-	ecn no	-	rel level	Released
TOLERANCES UNLESS OTHERWISE SPECIFIED		appr	Collins Lu	2014/12/18	product family	MINI-SAS HD	rel level	Released		
surface	✓	linear	0.X	±0.35		TITLE IX2 INTERNAL ASSEMBLY MINI-SAS HD	dwg no 10130812	rev A		
			0.XX	±0.25						
			0.XXX	±						
ASME Y14.5	angular		0°	±2°	www.fci.com	cat. no.	-	Product - Customer Drw	sheet 2 of 4	

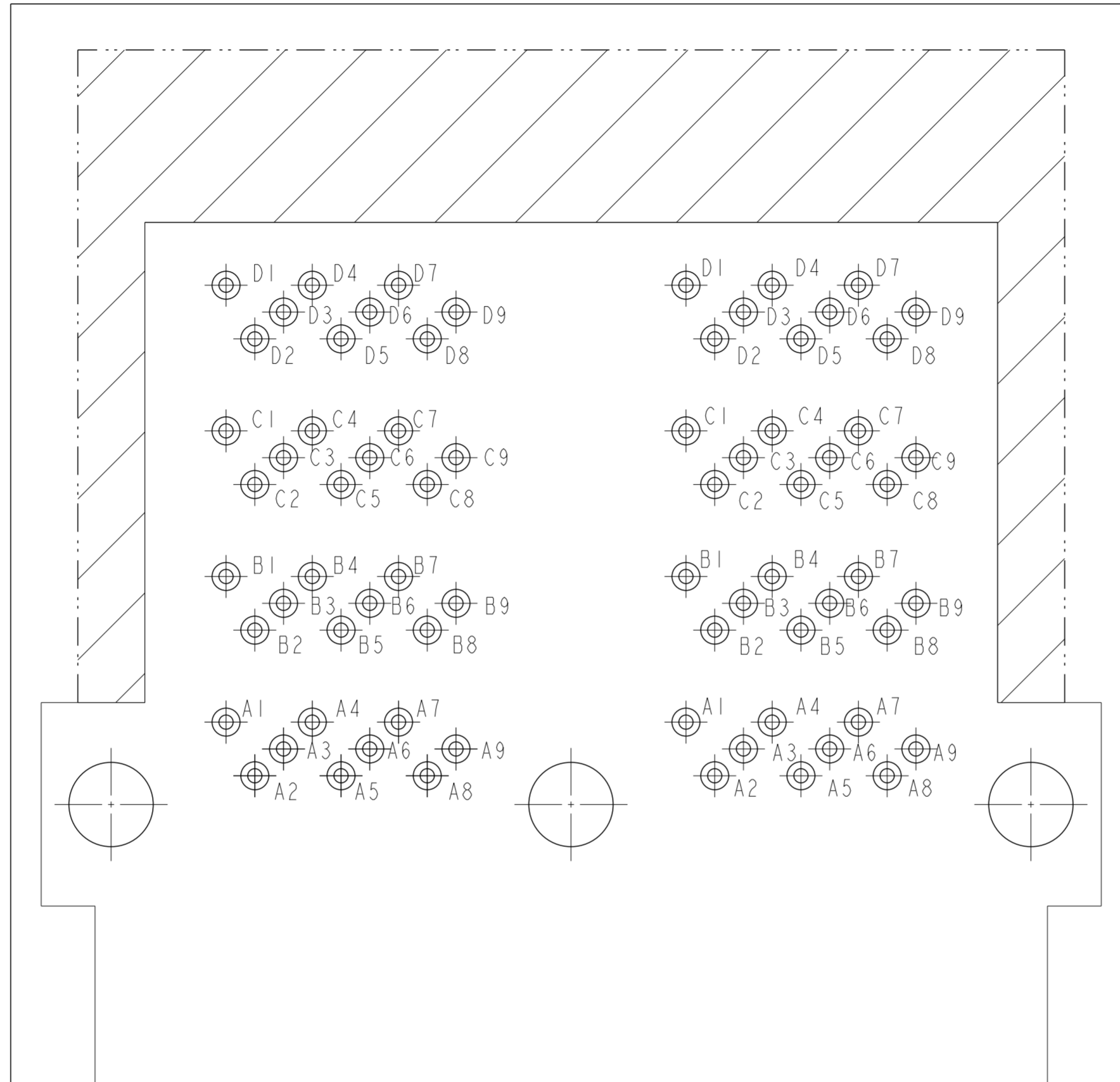

PIN OUT DESIGNATIONS



Copyright FCI.

spec ref	-	dr	Jackbin Zou	2014/07/07	projection	MM	size	A2	scale	2:1	
tolerance std	ASME Y14.5	eng	Jackbin Zou	2014/12/18			ecn no	-	rel level	Released	
TOLERANCES UNLESS OTHERWISE SPECIFIED		chr	-	appr							Collins Lu
surface	✓	linear	0.X	±0.35		title IX2 INTERNAL ASSEMBLY MINI-SAS HD	dwg no 10130812	rev A	Product - Customer Drw		
		angular	0°	±2°					cat. no.	-	sheet 3 of 4
ASME Y14.5									www.fci.com		

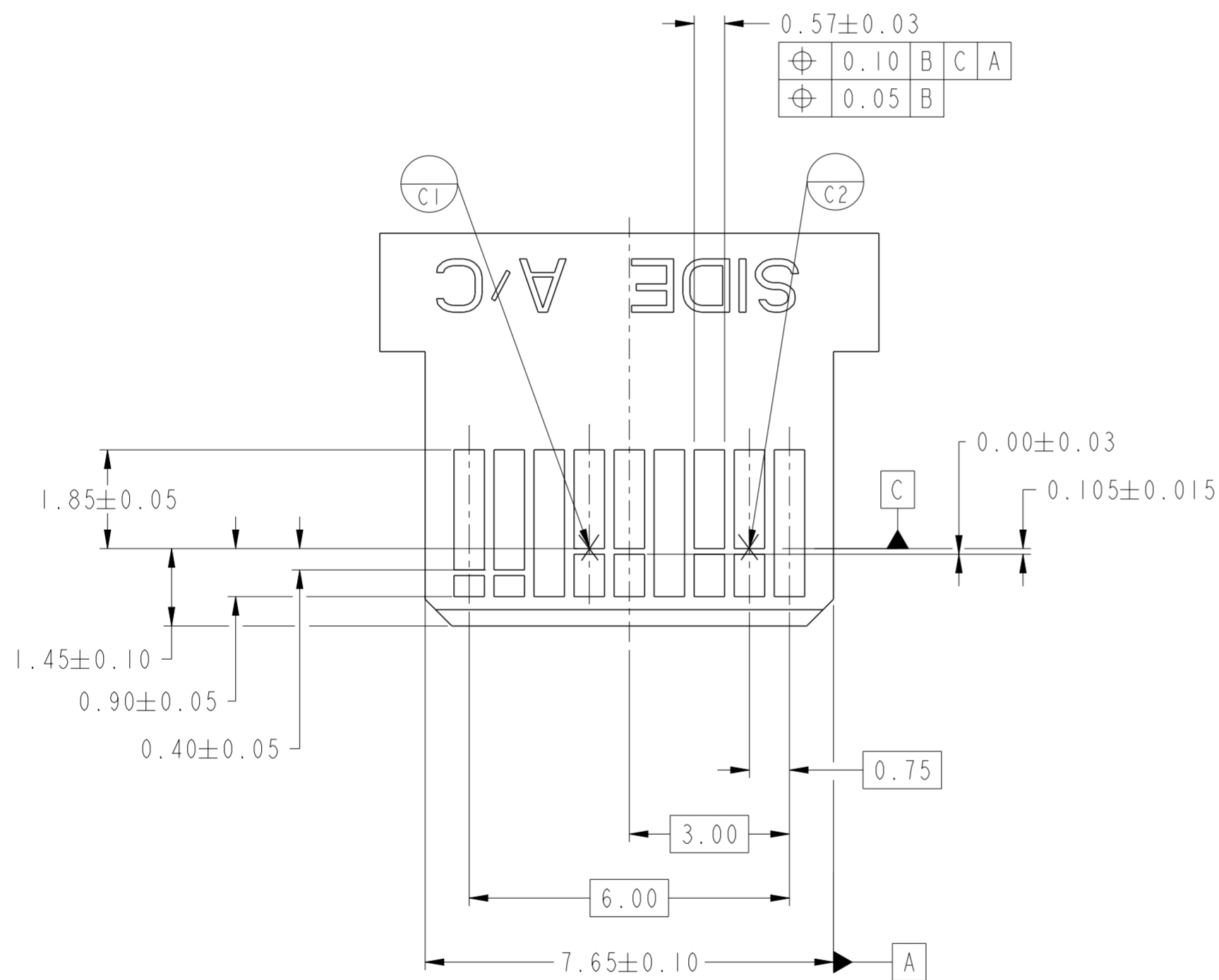
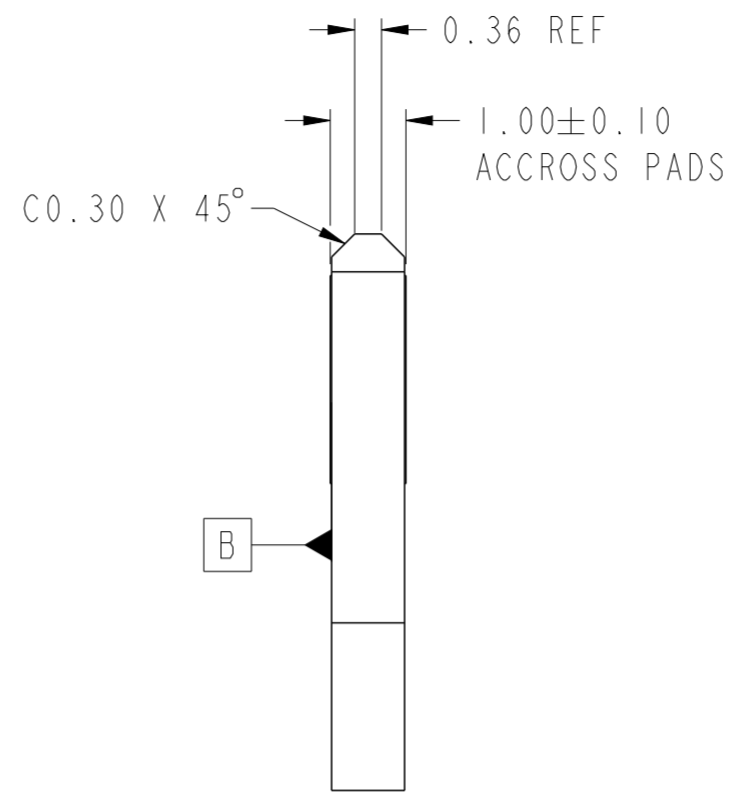
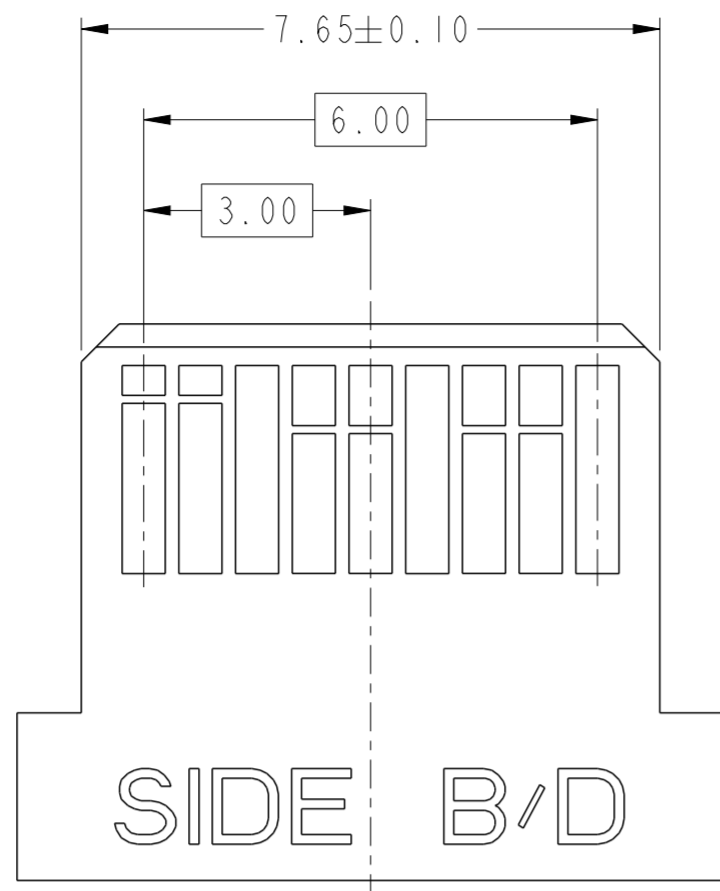

⊕	0.10	B	C	A
⊕	0.05	B		

NOTES:

- 0.05 MINIMUM KEEP OUT SOLDER MASK AROUND ALL PADS.
- DATUM C TARGETS ARE DEFINED BY THE RESPECTIVE PAD CENTER LINES AND THE LEADING EDGE OF THE TARGET PADS.

spec ref	-	dr	Jackbin Zou	2014/07/07	projection	MM	size	A2	scale	2:1
tolerance std	ASME Y14.5	eng	Jackbin Zou	2014/12/18	chr	-	ecn no	-	rel level	Released
TOLERANCES UNLESS OTHERWISE SPECIFIED		appr	Collins Lu	2014/12/18	product family	MINI-SAS HD	rel level	Released		
surface	✓	linear	0.X	±0.35		title IX2 INTERNAL ASSEMBLY MINI-SAS HD	dwg no 10130812	rev A		
		linear	0.XX	±0.25						
		linear	0.XXX	±						
		angular	0°	±2°	www.fci.com	cat. no.	-	Product - Customer Drw	sheet 4 of 4	

